



customer manual

SAFETY PRECAUTIONS	READ THIS FIRST !	2
1. INTRODUCTION		4
2. DESCRIPTION		4
2.1. Functional Description		5
2.2. Electrical Description		6
2.3. Machine Guard		6
2.4. Description of Operation		7
3. RECEIVING INSPECTION AND INSTALLATION		8
3.1. Receiving Inspection		8
3.2. Installation		8
3.3. Considerations Affecting Placement of Bench Machines		12
4. OPERATION		13
4.1. Control Panel		13
4.2. Applicator Setup and Installation		17
4.3. "Power On" Sequence		18
4.4. Condition After "Power On" Sequence		18
4.5. Stripping Module Errors		18
4.6. Stripping Module Removal		19
5. PREVENTIVE MAINTENANCE		20
5.1. Cleaning		20
5.2. Lubrication		20
5.3. Terminator Preventive Maintenance		20
6. DIAGNOSTICS		20
6.1. Software Version Identification		20
6.2. Input Monitor Mode		21
7. MECHANICAL ADJUSTMENTS		21
7.1. Strip Blade Closure Adjustment		22
7.2. Strip Length Adjustment		22
7.3. Wire Brush Adjustment		22
7.4. Gripper Adjustment		22
7.5. Tonk Adjustment		25
7.6. Strip Cam Speed Adjustment		25
7.7. Start Sensor Gap Adjustment		25
8. ELECTRICAL ASSEMBLY		26
9. PARTS REPLACEMENT		26
10. REVISION SUMMARY		26

CUSTOMER SERVICE CENTER**CALL TOLL FREE 1-877-671-2955**

The **ATS Customer Service Center** offers a means of providing technical assistance when required.

DANGER**SAFETY PRECAUTIONS AVOID INJURY**

Safeguards are designed into this application equipment to protect operators and maintenance personnel from most hazards during equipment operation. However, certain safety precautions must be taken by the operator and repair personnel to avoid personal injury, as well as damage to the equipment. For best results, application equipment must be operated in a dry, dust-free environment. Do not operate equipment in a gaseous or hazardous environment.

Carefully observe the following safety precautions before and during operation of the equipment:

- ALWAYS wear appropriate ear protection.
- ALWAYS wear approved eye protection when operating powered equipment.
- ALWAYS keep guard(s) in place during normal operation.
- ALWAYS insert power plug into a properly grounded receptacle to avoid electrical shock.
- ALWAYS turn off the main power switch and disconnect electrical cord from the power source when performing maintenance on the equipment.
- NEVER wear loose clothing or jewelry that may catch in moving parts of the application equipment.
- NEVER insert hands into installed application equipment.
- NEVER alter, modify, or misuse the application equipment.

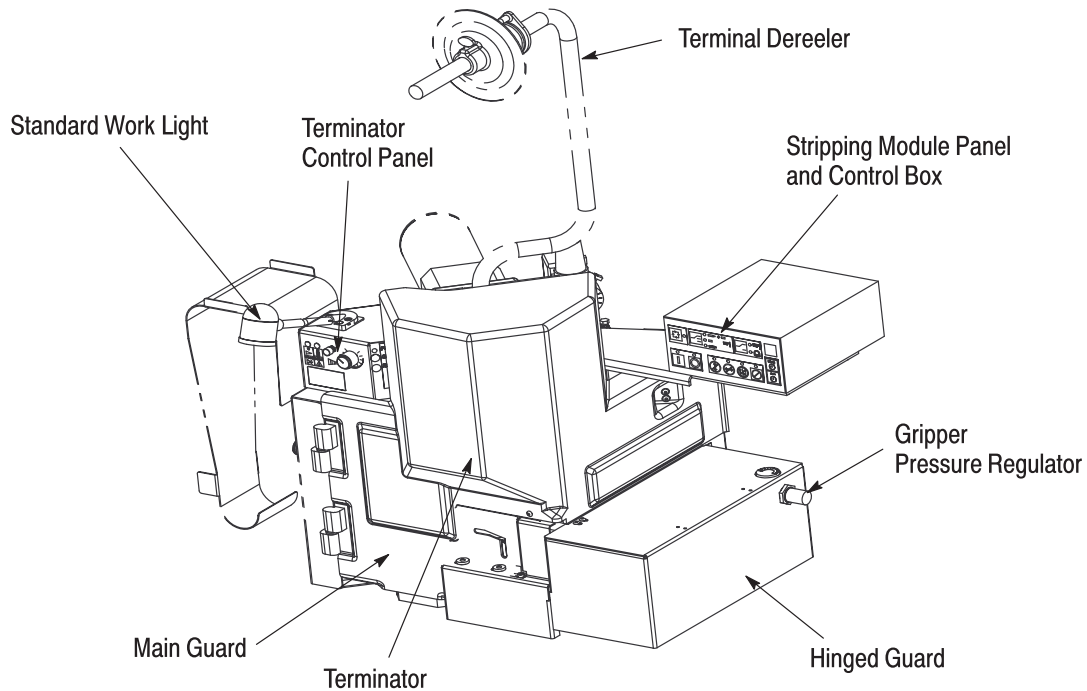

AVAILABLE STRIPPING MODULE KITS

Field Retrofit Kits for the Entry Level Terminator (Does not include Crimp Quality Monitor 1320420-1 and Cable 1320431-2 or Optional Work Light)

Stripping Module Kit	Part Number
Terminator w/o Crimp Quality Monitor	1490502-1
Terminator with Crimp Quality Monitor	1490502-2
1.5T Terminating Machine with Stripping Module	1725910-1
1.5T Terminating Machine with Stripping Module (CE Version)	1725910-2
1.5T Terminating Machine with Stripping Module and CQM	1725910-3
1.5T Terminating Machine with Stripping Module and CQM (CE Version)	1725910-4
2.5T Terminating Machine with Stripping Module	1725910-5
2.5T Terminating Machine with Stripping Module (CE Version)	1725910-6
2.5T Terminating Machine with Stripping Module and CQM	1725910-7
2.5T Terminating Machine Stripping Module and CQM (CE Version)	1725910-8
Factory Entry Level Terminator with Stripping Module (Includes Work Light)	
T-3000 with Stripping Module (Includes Precision Adjust)	1490500-2
T-3000 with Stripping Module (Includes Precision Adjust and CQM Sensors--Does not include Crimp Quality Monitor 1320420-1 and Cable 1320431-2)	1490500-7
T-3000 with Stripping Module (CE Version for Europe -- Includes Precision Adjust)	1490500-6
T-3000 with Stripping Module (CE Version for Europe -- Includes Precision Adjust and CQM Sensors -- Does not include Crimp Quality Monitor 1320420-1 and Cable 1320431-2)	1490500-9

Figure 1

1. INTRODUCTION

This manual contains information on the operation, adjustments and preventive maintenance of Stripping Modules 1490500-[] and 1725910-[] (factory installed stripping modules), as well as Stripping Module 1490502-[] (field retrofit kits), all used with the Model T-3000 Terminators and the 1.5T/2.5T Terminators. See Figure 1.

For information concerning the Model T-3000 Terminator, refer to 417-0003 and any documentation included with the terminator. For information concerning 1.5T/2.5T Terminators, refer to 417-0010 and any documentation included with the terminators.

Most side-feed and end-feed heavy-duty mini applicators and light-duty mini applicators can be run with stripping module. Slight modifications may be required to run these applicators; most modifications involve removing the wire stop. Refer to Paragraph 4.2, Applicator Setup and Installation.

Refer to the applicator instruction sheet and documentation included with the applicators for operation, adjustment, and preventive maintenance of the applicators.

When reading this manual, pay particular attention to DANGER, CAUTION, and NOTE statements.

DANGER Denotes an imminent hazard which may result in moderate or severe injury.

CAUTION Denotes a condition which may result in product or equipment damage.

NOTE Highlights special or important information.

2. DESCRIPTION

The Stripping Module is a pneumatically driven, microprocessor controlled, in-line stripping module designed to be used to provide wire stripping capability to the Entry Level Terminator bench machines. The terminator stripping module accepts a wide range of wire insulation types.

It is assembled with metric hardware.

NOTE Measurements are in metric units [followed by U.S. customary units in brackets]. Some commercial items may contain non-metric hardware.

Figure 2 contains specifications and requirements for the stripping module.

Wire Range Base Module:	0.03mm – 2.0mm (32–14 AWG)
Maximum Insulation:	5.08mm (.200 In.)
Cable Breakout:	Greater than 29mm (1.14 In.)
Strip Length:	2.54mm – 10.16mm (.100 In. – .400 In.)
Gripping Jaw Pressure:	Variable air pressure
Noise:	Less than 82dBa Typical at Operator Position with Standard Mechanical Feed Applicator
Weight:	4.55 Kilograms [10 lb.]
Height:	127mm [5 In.]
Electrical:	100–240 VAC, 50/60 Hz, single phase current
Air:	620–760 KPA [90–100 psi], 2.83 liters/sec (6 scfm)
Physical Environment (Temperature):	4.45 C to 605 C [405 F to 1045 F]
Altitude:	Not Applicable
Relative Humidity:	Less than 95% (non-condensing)
Transportation and Storage:	Store in a clean, dry environment after coating all surfaces lightly with a rust preventing oil.

Figure 2

2.1. Functional Description

The stripping module is a mechanism which will prepare discrete wire by stripping the insulation from the conductor for preparation of a crimp onto a terminal.

The machine consist of three functional areas.

The **transfer sub-assembly** consists of the side transfer block, applicator latches, and the transfer air cylinder. This sub-assembly provides a means of sliding the mechanism to the side so that the terminal may be applied to the wire.

The **gripper sub-assembly** consists of the upper and lower grip jaws, the gripper mounting block, the left and right gibs, the jaw drive block, and the gripper air cylinder. The gripper sub-assembly provides a means of holding the wire during the wire stripping and terminal application process. The gripper mechanism is "tonked" during the machine cycle to place the stripped wire in the terminal wire barrel.

The **stripping sub-assembly** consists of the U-block, the main block, the gibs, the blade drive block, the blade adjust block, the inner and outer strip blades, the start sensor block, start sensor arm, the start sensor, the start sensor air cylinder, the strip cam, and the strip air cylinder. This sub-assembly drives the inner strip blade to cut through the wire insulation. It also moves part of the mechanism away from the operator to pull the insulation slug off the wire. The mechanism also contains the wire start sensor to begin the cycle.

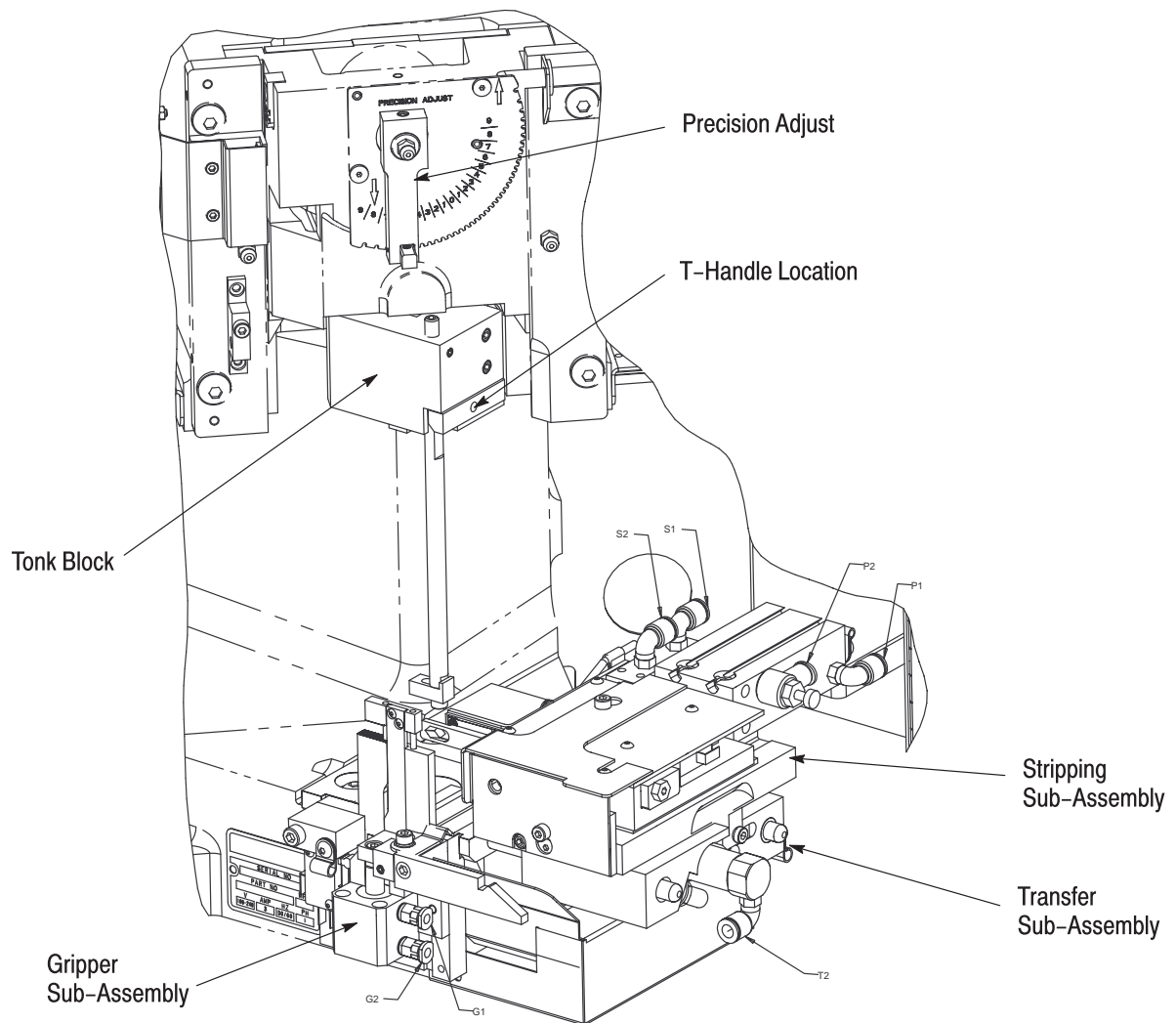

Figure 3 (Sheet 1 of 2)

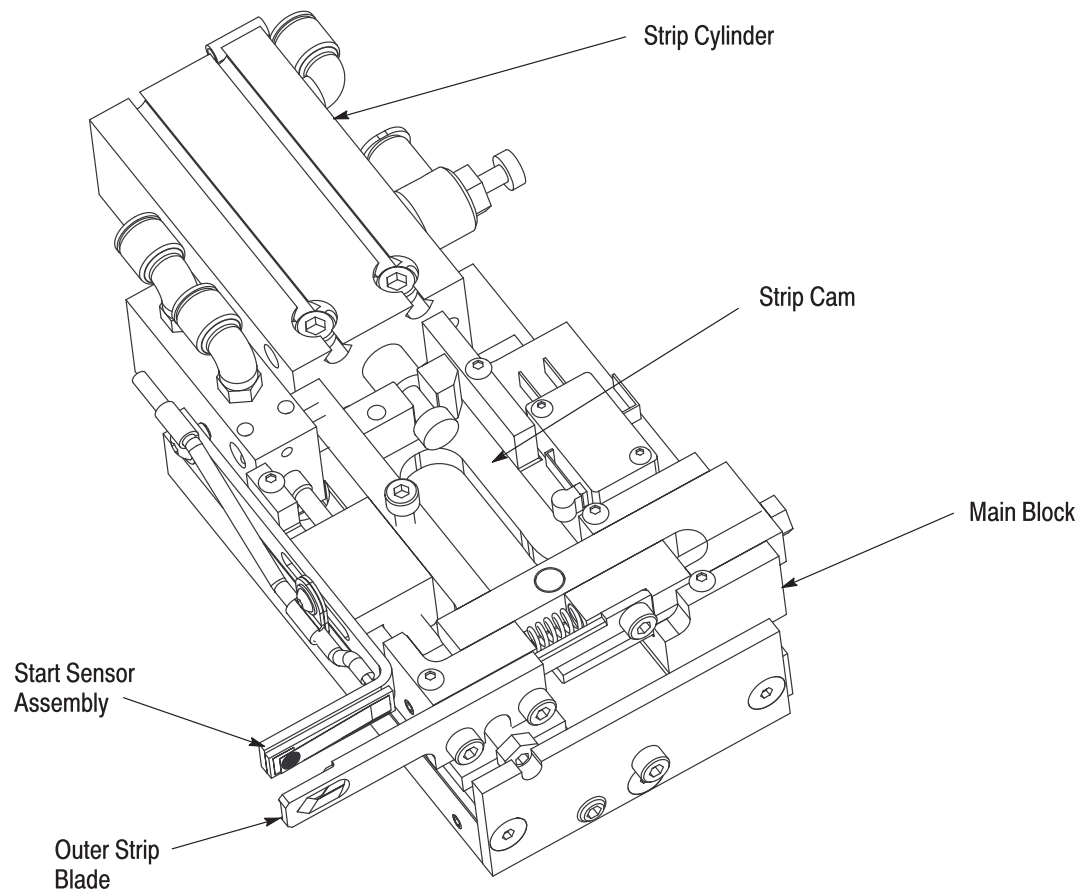

Figure 3 (Sheet 2 of 2)

2.2. Electrical Description

The stripping module electrical components consist of the operator control panel, the electrical enclosure, electrically controlled pneumatic valves, and various switches and sensors. The control module operates on 100/240 VAC, 50/60 HZ, single-phase current, with ground. Power for the control module is supplied by the terminator. The terminator power switch turns on both the terminator and the stripping module. A main power switch/circuit breaker is located on the back of the terminator electrical panel.

The operator control panel is attached to the electrical enclosure and is mounted on the right side of the machine. See Figure 1. The control panel consists of 12 indicator lights and 8 keys with icons depicting each function. Refer to Figure 9.

2.3. Machine Guard

A combination of guards is installed to provide protection for the operator while maintaining proper visibility of the work area. The main guard (Figure 1) swings open to the left and the hinged guard (Figure 1) swings open to the right to allow easy access for applicator installation and setup. Safety interlocks on the guards prevent the machine from cycling if the guard doors are open during production operation.

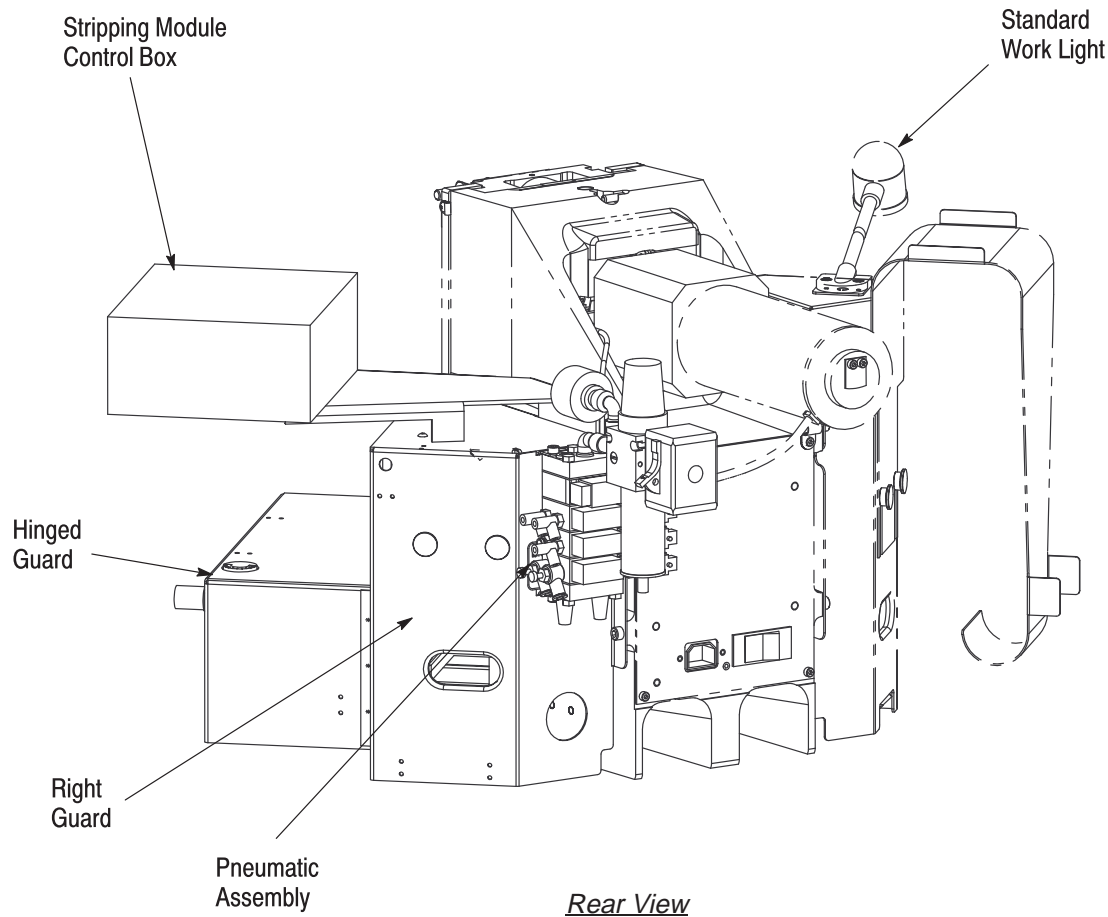

Figure 4

2.4. Description of Operation

The strip and crimp cycle of operation is as follows:

1. The cycle may be started automatically (with "Start Sensor" selected as the starting means), or with the foot switch. In automatic operation ("Start Sensor" selected as the starting means), the operator places a wire through the grip jaws and strip blades to depress the start sensor, which automatically starts the cycle. If the foot switch was selected as the starting means, the operator depresses the foot switch to activate the cycle.
2. The gripper jaws then close on the wire while the strip blades close to cut through the insulation. The stripping mechanism pulls the blades away from the operator to remove the insulation slug.
3. The stripping unit shifts to the "right side position" to remove the stripping blades from the applicator.
4. The terminator cycles to crimp a terminal onto the wire.
5. After completing the crimp, the grippers open to release the crimped wire and the stripping blades retract.
6. The start sensor arm then retracts so that the air blast can blow the insulation slug into the scrap bin.
7. The stripping unit then transfers back to the start position.

3. RECEIVING INSPECTION AND INSTALLATION

3.1. Receiving Inspection

The Stripping Module is thoroughly inspected during and after assembly. A final series of inspections is made to insure the proper machine functioning before packaging and shipping.

To protect against damage that may have occurred during shipment, remove the machine from the packaging and carefully inspect the machine for damage. If damage is evident, file a claim against the carrier and immediately notify Tyco Electronics.

DANGER

To avoid personal injury, be sure to turn "off" and disconnect power to the machine.

3.2. Installation

Remove the module from the packaging and install the field kit to the machine as follows:

A. Terminator Preparation

1. Disconnect electrical and pneumatic power supplies.
2. Remove the applicator, terminal reel, strip guide, and reel support.
3. Remove the main guard by lifting it out of the hinges. Replace the guard with the new main guard, leaving the hinges and interlock key in tact.
4. Remove the electrical panel from the rear of the terminator.
5. Disconnect the cables going to the terminator board at J11, J12, J4, and J6. See Figure 5. Completely remove the footswitch cable, clamp, and ground wire from the terminator board.
6. Disconnect the wires connecting to the terminator main power switch at terminal 3 and terminal 4 (Figure 5).
7. Remove the operator interface assembly from the terminator.
8. Remove the cable from connector J1 of the operator interface. This cable will be replaced.
9. Remove the door switch from the terminator right guard. Save the switch.
10. Remove the right guard from the terminator. The right guard will be replaced by a new right guard.
11. Remove the base plate assembly from the Entry Level Terminator. The rear stops, the clamp, the "T" handle, the screws and spring will be re-used.

B. Installation of the Stripping Module Field Kit 1490502 -[] in the Terminator

NOTE

Refer to Drawing 1490842 for hose and cable routing. Refer to Drawing 1490502 for component placement.

1. Install the old rear stops, clamps, and spring onto the new base plate. Install special screw 1490819-1 in place of the "T" handle.
2. Install the new base plate on the terminator using the existing button head screws.

NOTE

Do NOT fully tighten the button head screws yet.

3. Install an applicator and check for proper alignment of the applicator ram in the adaptor post of the terminator. Move the base plate as necessary to achieve proper alignment.
4. Remove the applicator and tighten the button head screws securing the terminator base plate.
5. Check the shut height of the terminator using a shut height gage. Adjust if necessary.
6. Install the new right guard.
7. Install the pneumatic assembly onto the rear of the right guard.

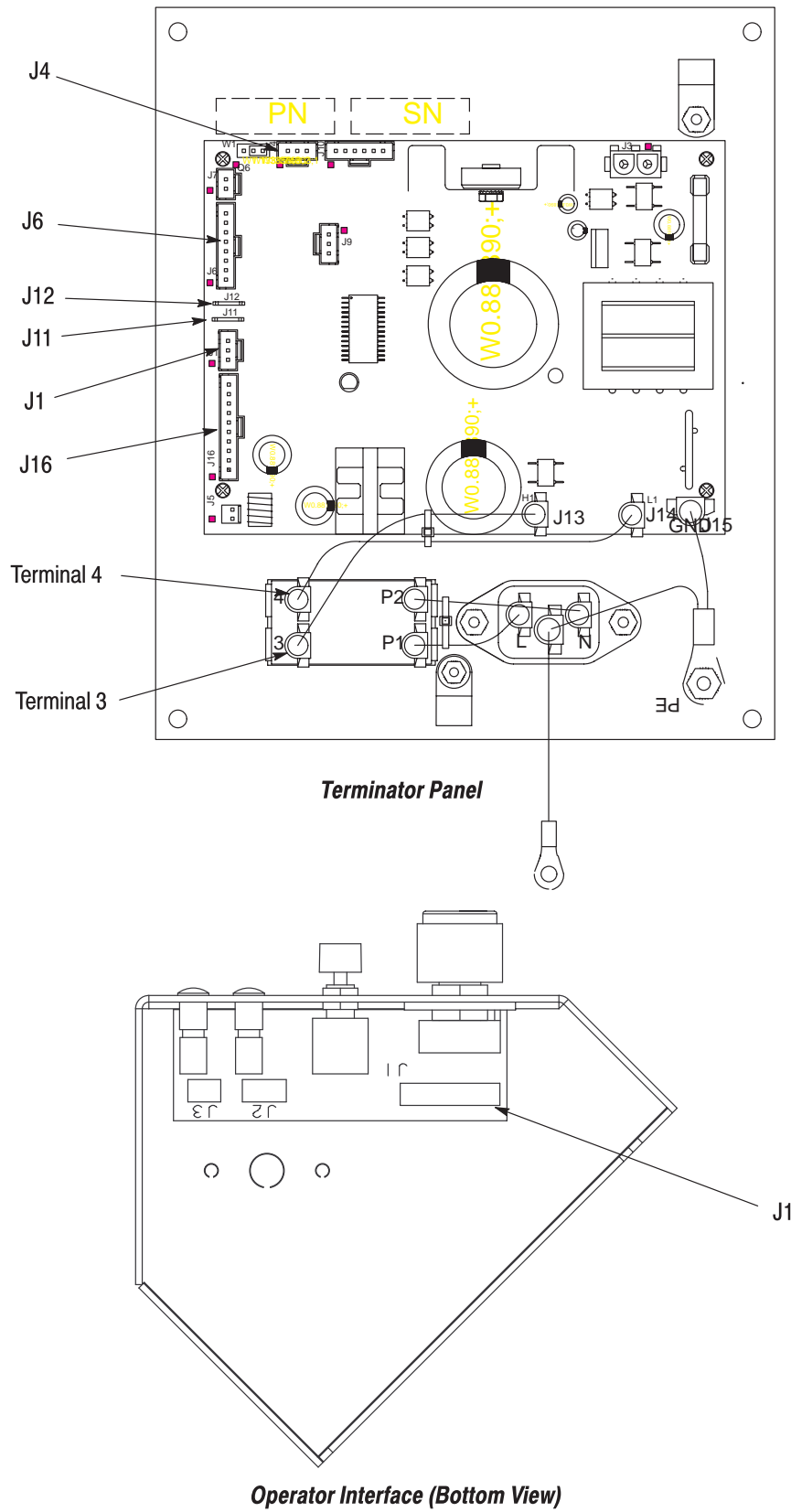

Figure 5

8. Install the interlock switch and pass the wire through the hole in in the upper corner of the right guard. Refer to Drawing 1490842, Sheet 9. Do NOT fully tighten the screws at this time.
9. Install the new operator interface cable cable (Cable M) into J1 of the operator interface.
10. Install the operator interface on the terminator. Route the cable as shown in Drawing 1490842, Sheet 12.
11. Remove the old door hinges and interlock key from the old main guard and install on the new main guard. Adjust the hinges as necessary, so that the door closes properly.
12. Close the door completely, so that the interlock key is fully engaged in the interlock switch. Tighten the screws to the interlock switch.
13. Install Crimp Quality Monitor Bracket 1338979-1 on the right-hand side of the terminator.
14. Install Control Box Assembly 1490593-1 onto the Crimp Quality Monitor bracket.
15. Mount the top dead center (TDC) switch and bracket 1490796-1 as shown in Drawing 1490842, Sheet 8. Adjust the switch so that it is 1mm from the terminator ram.
16. Install the tonk block (Item 4 on Drawing 1490502) on to the terminator adaptor post.

NOTE

During installation, BE SURE to push the block against the underside of the terminator ram.

17. Install the tonk rod, tonk foot, lever, and "T" handle of the old base.
18. Loosen (but do not remove) the two set screws that hold the tonk block to the adaptor post.
19. Be sure the transfer mechanism is pushed to the right position.
20. Manually cycle the terminator to bring the tonk foot down to the lower grip jaw. Move the tonk foot (forward or backward) to align the tonk foot to the lower grip jaw.
21. Install and route the wires, air line tubing, and cable ties, as shown in Drawings 1490842 and 1490782.
22. Install the following to the terminator board:
 - a. Install Foot Switch Cable K (P22 to J11, and P21 to J12).
 - b. Install Operator Interface Signal Cable N to J6.
 - c. Install Interlock Signal Cable L to J4.
 - d. Install AC Power Cable H.
 - Install the brown wire (P20) onto terminal 3 of the rocker switch.
 - Install the blue wire (P19) onto terminal 4 of the rocker switch.
 - Install the brown wire from the terminator back onto piggy-back connector on terminal 3.
 - Install the blue wire from the terminator back onto the piggy-back connector on terminal 4.
 - e. Ground Cable P to the ground stud on the terminator board.
 - f. Connect the FASTON tab on Ground Cable P to the FASTON receptacle of AC Power Cable H.
23. Install the following to the stripping module control board:
 - a. Install Interlock Signal Cable L to J11 (from the terminator board).
 - b. Install Interlock Switch Cable to J10 (from the interlock switch).
 - c. Install Foot Switch Signal Cable K.
 - Install P7 to J7.
 - Install P8 to J8 (from the terminator board).
 - d. Install Terminator Operator Interface Cable M to J6 (from the terminator operator interface).
 - e. Install Terminator Operator Interface Cable N to J9 (from the terminator board).
 - f. Install the terminator foot switch cable to J17 and J18 (from the foot switch).
 - g. Attach the ground from the footswitch to the screw on the back of the control box (refer to Drawing 1490842).

24. The following cables exit through the gland nuts on the stripping module control board and *must* be attached to the machine. See Drawing 1490842 and attach as follows:

- Tooling-in-Place Switch Cable C1 to transfer subassembly (refer to Sheet 6);
- Pull-back Switch Cable D1 to stripping subassembly (refer to Sheet 4);
- Tonk Switch Cable D2 to gripper subassembly (refer to Sheet 3);
- Side Transfer Switch Cable C2 to transfer subassembly (refer to Sheet 6);
- Wire Start Sensor Cable B to stripping subassembly (refer to Sheet 5);
- Terminator TDC Switch Cable J to TDC switch by the terminator ram (refer to Sheet 8); and
- Air Valve Cable E to the pneumatic assembly on the right guard (refer to Sheet 10).

25. Install the cover on the electrical box.

26. Install the electrical panel on the rear of the terminator machine.

27. Connect electrical power to the terminator.

28. Turn the machine “on” in the INPUT MONITORING Mode and check for proper functioning of the machine inputs by manually cycling the stripping module. Refer to Paragraph 6.2.

When the unit appears to be functioning properly proceed as follows:

1. Remove the applicator.
2. Manually return the terminator ram to the top of its travel (TDC).
3. Connect air and turn “on” the main air shut-off valve.
4. Close the guard
5. Power up the stripping module by pressing the green Power Up Button.
6. Check for errors that may have occurred while the machine was being turned on.
7. Use the error code table in Paragraph 4.5 to diagnose and correct any errors.

C. Installation of Terminator and Stripping Module 1490500-[]

Remove all mounting bolts securing the terminator to the shipping pallet. Install lift ring (see Figure 6) on top of the machine.

NOTE

Lift ring (M12 X 20 eye bolt) is customer supplied.

CAUTION

*Install the lift ring **carefully**. A 19.05-mm [.75-in.] thread length engagement is required for the lift ring to support the machine.*

Attach a suitable hoist to the lift ring, lift the machine, and place it in the selected operating location.

Insert the reel support post into the appropriate hole on top of the machine until the roll pin engages a groove in the machine frame.

Attach the terminal strip guide included with the machine with the two thumbscrews supplied. Mount the guide on the left guard for side-feed applicators. Mount the guide on the right guard for end-feed applicators.

Connect the power cord to a suitable electrical supply.

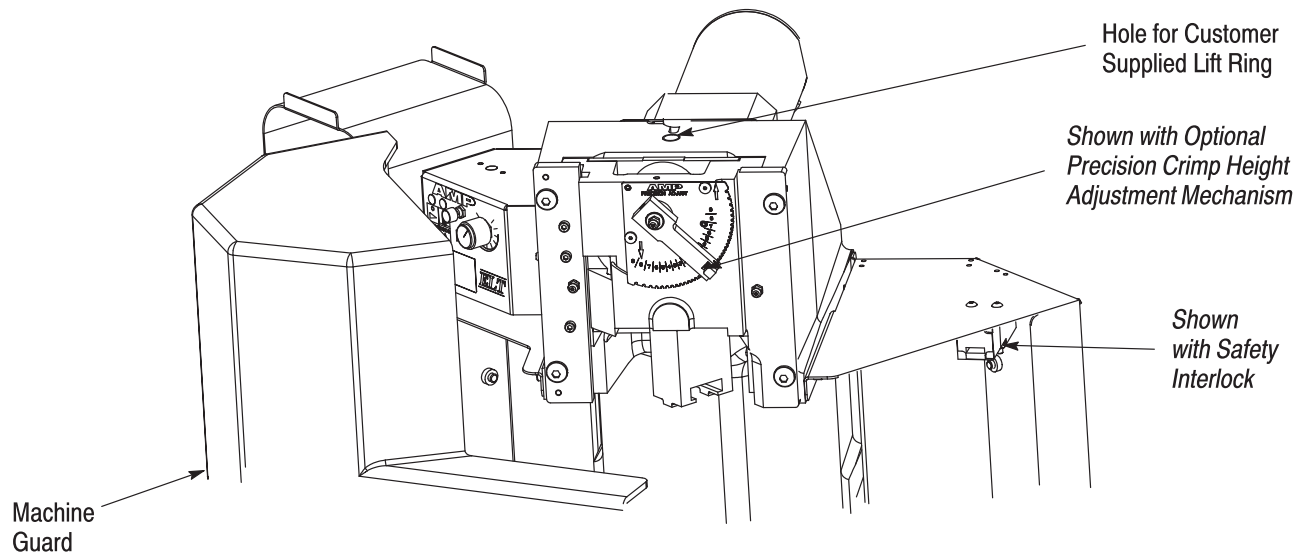

Figure 6

NOTE

The machine will automatically detect the supply voltage and adjust the controller accordingly.

NOTE

Models exported to Europe will be installed by Tyco Electronics Service Engineers. These engineers will verify that the electrical and pneumatic connections are correct. Both pneumatic and electrical connections must be installed in a way that provides a lockable isolation switch for hard-wired or direct piped machines. This is necessary to interrupt power to the machine for setup or maintenance.

Connect the pneumatic assembly to a suitable air supply.

Turn the machine “on” in the INPUT MONITORING Mode and check for proper functioning of the machine inputs by manually cycling the stripping module. Refer to Paragraph 6.2.

When the unit appears to be functioning properly proceed as follows:

1. Remove the applicator.
2. Manually return the terminator ram to the top of its travel (TDC).
3. Connect air and turn “on” the main air shut-off valve.
4. Close the guard
5. Power up the stripping module by pressing the green Power Up Button.
6. Check for errors that may have occurred while the machine was being turned on.
7. Use the error code table in Paragraph 4.5 to diagnose and correct any errors.

3.3. Considerations Affecting Placement of Bench Machines

The location of the machine in relation to the operator’s position is extremely important in terms of both safety and maximum efficiency. Studies have repeatedly shown that operator fatigue will be reduced, and greater efficiency achieved, if: (1) the bench is of appropriate height, preferably with sound-deadening rubber mounts; (2) the machine is properly located on the bench with ample work areas on both sides to facilitate work flow; (3) the operator uses a swivel chair with padded seat and back rest which are independently adjustable; and (4) the foot switch, on machines so equipped, is placed on a rubber mat to maintain its movability, while preventing it from sliding unintentionally. Figure 7 illustrates proper machine location and operator position. Figure 8 illustrates:

1. Bench

The bench to be used should be of sturdy construction, preferably with rubber mounts to minimize noise. A height of 762.0mm to 812.8mm [30 in. to 32 in.] is the most suitable for operator comfort and

convenience. This height allows the operator to rest both feet on the floor, thereby providing for the shifting of weight and leg position.

2. Machine Location on Bench

The machine should be located near the front of the bench with the “target area” (tooling area where the product is applied) not more than 152.4mm to 203.2mm [6 in. to 8 in.] from the front edge. This location will eliminate unnecessary operator motion and help to avoid back strain and fatigue.

Orientation of the machine should be such that the “target area” is facing the front of the bench and is parallel to the front edge. (Access to the back of the machine MUST also be provided.)

3. Operator’s Chair

The operator’s chair should swivel, and should have independent seat height and back rest adjustments. The seat and back rest should be padded, and the back rest should be large enough to provide support both above and below the waist line.

In use, the chair should be far enough under the bench so that the operator’s back is straight and is supported by the back rest.



Figure 7

Materials Locations — Plan View

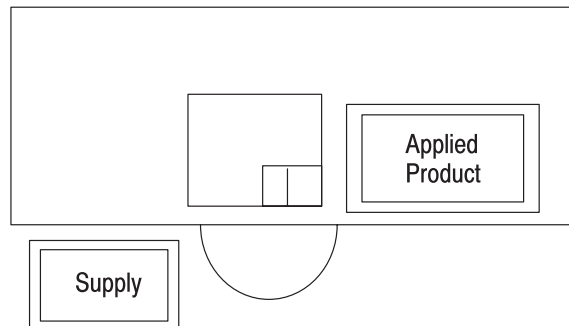
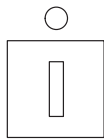
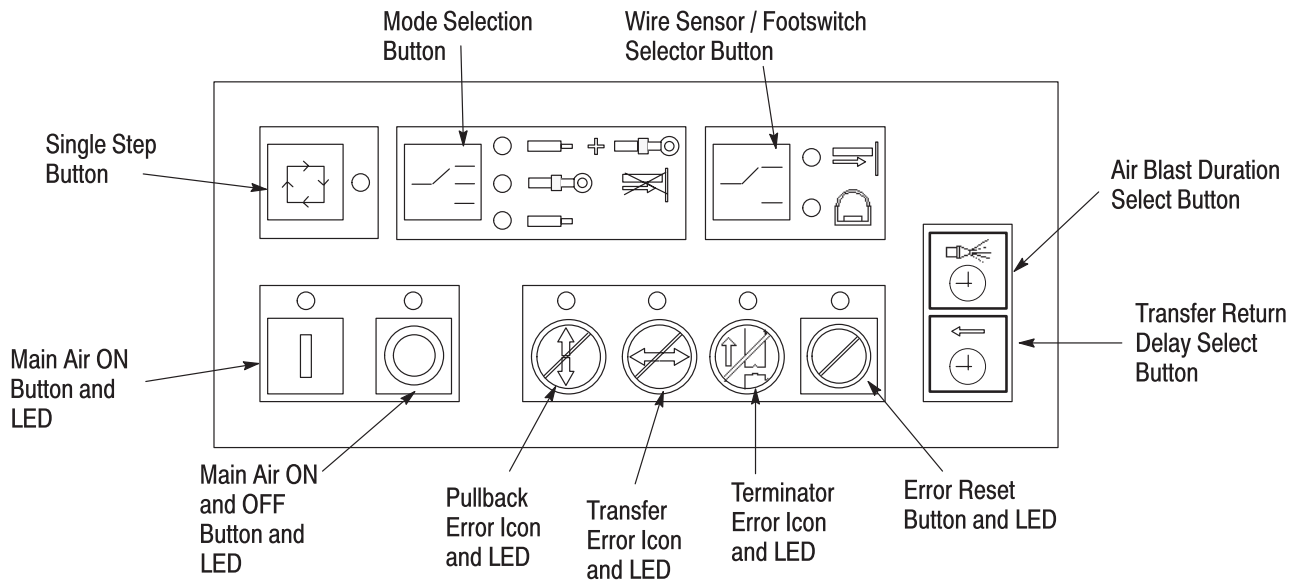

Figure 8

4. OPERATION

4.1. Control Panel

The stripping module is operated using the control panel shown in Figure 9.



Pushing the **Main Air ON Button** causes the main air valve to pulse, “homing” the stripping mechanism. After “homing,” the mechanism returns to the start position for mode selected. The **Power ON LED** will turn “on” when the power on sequence is complete.

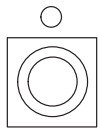

Pressing the **Main Air OFF Button** turns off the main air valve, removing pneumatic power. The **Main Air OFF LED** will be “on” when the main air valve is turned “off.”

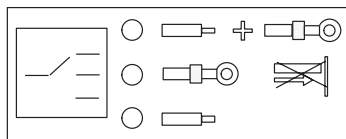

The **Mode Selection Button** toggles the machine mode to the next mode. The three available modes include: Strip and Crimp Mode (top); Crimp Only Mode (middle); and Strip Mode Only (bottom). Each press of the button toggles the machine between modes.

Note that the Main Air must be OFF to change modes.

Note that the Crimp Only Mode precludes the use of the wire sensor for starting the cycle.

The corresponding LEDs designate the currently selected mode.

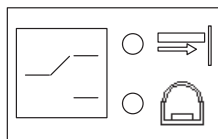

Pushing the **Wire Sensor Button** toggles between the Wire Sensor method (top) and the Footswitch method (bottom) of operation. Only one method of starting can be selected for operation. The Wire Sensor LED will indicate the selected method of operation.

The wire sensor method of operation is used in the Strip and Crimp Mode and the Strip Only Mode.

The footswitch method of operation is used for *all* modes. In addition, the **Footswitch LED** will turn “on” during Single Step Operation to indicate that a terminator cycle may occur, either by jogging with the Jog button or automatic cycle by pressing the foot switch

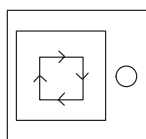

Pressing and holding the **Single Step Button** places the system in single step operation. Each additional press of the button initiates the next step of the machine cycle. When the cycle is complete, the system will return to normal operation and the **Single Step LED** will be turned off.

Figure 9 (Sheet 1 of 3)

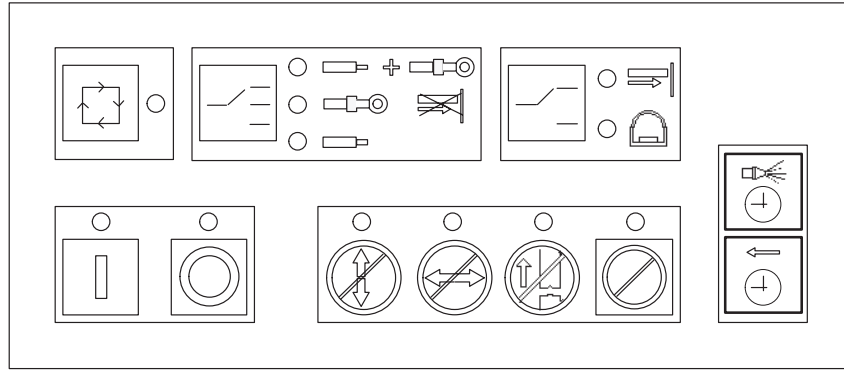

When lit, the LED above the **Pullback Error Icon** indicates that the gripping stripping tooling has not completed the retracted or extended function of the operation. *Observe the error code displayed by the **Error Reset LED** for additional information describing the error.*



When lit, the LED above the **Transfer Error Icon** indicates that the gripping stripping tooling has failed to transfer to the right or left. *Observe the error code displayed by the **Error Reset LED** for additional information describing the error.*



When lit, the LED above the **Terminator Error Icon** indicates that the terminator has failed to complete its cycle. *Observe the error code displayed by the **Error Reset LED** for additional information describing the error.*



The function of the **Error Reset Button** is to reset an existing stripping or crimping error. When an error occurs, the **Error LED** will blink a code that indicates the current error. (See Paragraph 4.4.) The error code is repeated continuously until acknowledged and cleared by pressing the Error Reset Button. *If the error occurs in the Pullback, Transfer, or Terminator section, the corresponding Error LED will also be illuminated.*

Figure 9 (Sheet 2 of 3)

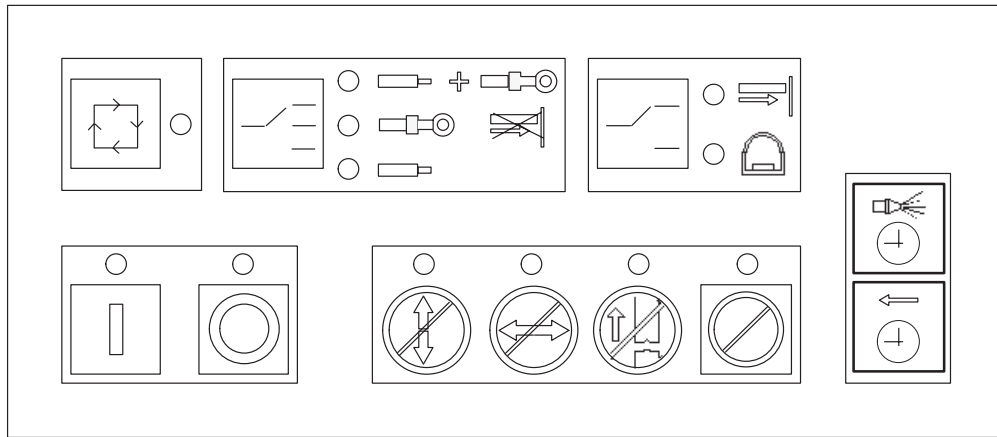

The **Air Blast Duration Select Button** provides a means of selecting one of four preset durations for the air blast pulse. To set the level, press and hold the **Air Blast Duration Select Button** for about one second until all the error LEDs turn on. Releasing the button will allow one to four LEDs to remain lit, indicating the level of the air blast. Momentarily pressing the **Air Blast Duration Select Button** will toggle through the levels. When the desired level is reached, press and hold the **Air Blast Duration Select Button** until the error LED indicators turn off. The new level is automatically stored. Releasing the button returns the stripping module to normal operation,

Each LED corresponds to a preset air blast duration, increasing in duration from left to right. The illuminated LED corresponds to the currently selected duration of the air blast. The more LED's illuminated, the longer the duration of the air blast. (One LED lit indicates the shortest air blast; four LEDs lit indicates the longest air blast.)



The **Transfer Return Delay Select** Button provides a means of selecting one of four preset delays. The delay occurs after the air blast to allow the operator more time to remove terminated wire before the strip assembly returns to the start position. To set the level, press and hold the **Transfer Return Delay Select** button for one second until all the error LEDs are lit. Releasing the button will leave on one to four LEDs, indicating the level of the delay. (One LED lit indicates the shortest delay; four LEDs lit indicates the longest delay.) When the desired level is reached, press and hold the button until all the error LEDs turn off.

The new level is automatically stored. Releasing the button returns the stripping module to normal operation.

Momentarily pressing the **Transfer Return Delay** button will toggle through the levels.

Figure 9 (Sheet 3 of 3)

4.2. Applicator Setup and Installation

A. Side-Feed/End-Feed Applicator Preparation

Prepare side-feed applicators for use with the stripping module by removing the applicator wire stop. Prepare end-feed applicators for use by removing the applicator wire stop and moving the track-mounted “hold down” back as far as possible.

Install the applicator onto the terminator (Paragraph 4.2,C). Adjust the wire brush and strip length and check for any interferences. If interference with the track-mounted “hold down” exists, remove the track-mounted “hold down.”

B. Terminal Sticking Elimination/Prevention

Certain types of terminals are more likely to stick in the crimpers than other types. In many types of application equipment, the wire stop acts as a terminal stripper. When using the stripping module, however, the wire stops must be removed.

Besides removing the applicator wire stop, the following methods may be used to eliminate/prevent terminal sticking:

- Use a terminal lubricator.
- Use a spring-loaded, ram-mounted wire depressor mounted between the crimper and the wire barrel crimper.
- Use a ram-mounted terminal “hold-down” commonly found on end-feed applicators.

C. Applicator Installation/Removal

It may be necessary to install the applicator from either the left side or the right side of the gripper mechanism, depending on the applicator and type of product being run. Instructions for installing the applicator from the left side *and* the right side are listed below.

To remove the applicator, disconnect power to the machine and remove in reverse order of installation.

Left-Side Installation

DANGER

To avoid personal injury, be sure to disconnect power to the module and the terminator before installing or removing the applicator.

1. Slide the stripping module and movable part of the transfer assembly to the right side position.
2. Remove the tonk from the ram post adapter.
3. Loosen the screw holding the scrap deflector and rotate the scrap deflector toward the front of the machine.
4. Loosen the applicator latch on the machine base plate and push it out of the way.
5. From the left side of the gripper assembly, tilt the applicator and place it in position on the base plate.
6. Slide the applicator ram into the ram post of the terminator.
7. Place the left (applicator) latch on the terminator into the slots on the applicator base plate.
8. Lift the right (applicator) latch and tighten against the applicator base plate.
9. Rotate the scrap deflector back against the applicator base plate and tighten the hold down screws
10. Install the tonk into the ram post adapter.
11. Manually cycle the terminator and stripping module to verify fit, clearance, and proper operation.

Right-Side Installation

DANGER

To avoid personal injury, be sure to disconnect power to the module and the terminator before installing or removing the applicator.

1. Remove the upper portion of the strip assembly by loosening the locking latch on the right side of the transfer assembly.
2. Lift the strip assembly off the transfer assembly and set it on a work bench.
3. Remove the tonk from the ram post adapter.
4. Loosen the screw holding the scrap deflector and rotate the scrap deflector toward the front of the machine.
5. Loosen the (applicator) latch on the machine base plate and push it down out of the way.
6. From the right side, place the applicator on the base plate.
7. Slide the applicator ram into the ram post of the terminator.
8. Place the left (applicator) latch on the terminator base plate into the slots on the (applicator) base plate.
9. Lift the right (applicator) latch and tighten it against the applicator base plate.
10. Rotate the scrap deflector back against the applicator base and tighten the hold down screws.
11. Place the upper portion of strip assembly back on the transfer assembly.
12. Partially tighten the locking latch.
13. Push the upper portion of the strip assembly toward the rear of the machine until the wire brush adjustment screw bottoms on the rear stop.
14. Install the tonk into the ram post adapter.
15. Manually cycle the terminator and stripping module to verify fit, clearance, and proper operation.

4.3. “Power On” Sequence

When AC power is first applied to the terminator and stripping module controller, all the LEDs on the console will turn on briefly and then turn off momentarily. The necessary LEDs will then turn back on. The controller will then display any internal controller errors using the Error LED. Refer to Paragraph 4.5. An error detected at this time will not be able to be reset. If no internal errors were encountered:

- a. the **Power Off LED** will turn “on;”
- b. the **LED** for the current cycle start method will turn “on;” and
- c. the LED indicating the last selected operating mode will also be turned “on.”

4.4. Condition After “Power On” Sequence

After the “Power On” sequence has completed, the **Power On LED**, the LED for the current mode, and the LED for the current cycle start method will turn “on.”

4.5. Stripping Module Errors (Error Reset Button and LED Code)

In addition to the Pullback, Transfer and Terminator errors described in Figure 6, the following errors will be reported by the controller. The error will be displayed by flashing the Error LED the indicated number of times indicated in Figure 10.

Stripping Module Controller Error Codes

Flashes	Error
1	(Error code not used)
2	Guard was opened.
3	Guard must be closed.
4	Switch did not “unmake” within the allotted time.
5	Switch did not “make” within the allotted time.
6	Faulty switch detected.
7	Tonk switch is faulty.
8	Did not sense tonk switch.
9	Tonk mechanism is stuck “down.”
10	Terminator is not at top–dead–center (TDC) position
11	Stripper unit Main Air is “off.”
12	Tooling is not in machine.
13	Wire sensor is bad or stuck in the “on” position.
14	Footswitch is bad or stuck in the “on” position.
15	Controller failed to detect the “Power Up” of the Entry Level Terminator.
16	Bad footswitch input detected.
17	Bad keypad detected.
18	Bad spare input detected.
19	Transfer mechanism is not shifted to the right.
20	Bad wire sensor input detected.

Figure 10

4.6. Stripping Module Removal

The stripping module may need to be removed when changing applicators (refer to Paragraph 4.2,C for applicator installation procedures).

DANGER

To avoid personal injury, be sure to disconnect power to the module and the terminator before installing or removing the stripping module.

1. Loosen the cap screw located at the right side of the module.
2. “Back off” the clamp on the right side of the module.
3. Slide the module to the right and lift “up,” to removing the module from the mounting base.

5. PREVENTIVE MAINTENANCE

Preventive maintenance will keep the stripping module in good working order and ensure maximum reliability and service from all of its components.

DANGER *To avoid personal injury, electrical and pneumatic power must be DISCONNECTED at the source prior to maintenance.*

5.1. Cleaning

Clean any debris from the stripping module daily.

DANGER *Compressed air used for cleaning must be reduced to less than 207kPa [30 psi], and effective chip guarding and personal protective equipment (including eye protection) must be used.*

If an air-feed assembly is installed, check and replace the air filter element if necessary.

Wipe off the guards with a clean soft cloth.

CAUTION *DO NOT USE ANY SOLVENT TO CLEAN THE GUARDS. Solvent could damage the guards.*

Remove the stripping assembly and proceed as follows:

- a. Thoroughly clean both the stripping assembly and the area in and around the base plate.
- b. Inspect the stripping assembly for damaged parts, clean the assembly and remove all insulation scrap and wire strands.
- c. Remove all insulation scrap and wire strands from the gripper assembly.
- d. Re-install the stripping assembly.

5.2. Lubrication

Lubricate all sliding surfaces with a general purpose grease at least every 250,000 cycles.

NOTE *Apply grease to groove in the bottom of the strip cam.*

Apply light weight oil to the surfaces of the strip blades.

CAUTION *Do NOT get oil on the cutting surfaces of the blades, or sticking of the insulation slug may occur.*

Use a grease gun to apply grease to the transfer assembly through the grease fitting at least every million cycles.

NOTE *It is necessary to remove the Tooling-in Position Switch to gain access to the grease fitting.*

5.3. Terminator Preventive Maintenance

For preventive maintenance procedures for the terminator, refer to customer manual 417-0003 or 417-0011.

6. DIAGNOSTICS

6.1. Software Version Identification

1. Turn “off” power to the machine and the Stripper Controller.
2. Turn the system “on” and wait for the Stripper controller operator interface LEDs to be turned on.
3. When the LEDs come on, press and hold the **Single Step** button (refer to Figure 6). The Single Step LED will then flash the software version, similar to the way the terminator flashes it’s software version.

NOTE *The software version will be repeated as long as the **Single Step** button is depressed.*

The format for the software version is “X. Y. Z.” where:

- X represents the major software revision,
- Y represents the secondary software revision, and
- Z represents the minor software revision.

The “.” between each number is represented by a pause.

When the entire version is finished blinking, a one-second delay will be observed. Following the delay, the software version will be repeated. Thus, a software version of “1.2.3” would be represented as:

- Flash
- (Short Pause)
- Flash, Flash
- (Short Pause)
- Flash, Flash, Flash
- (One-second pause)

Following the one-second pause, the process will repeat itself.

6.2. Input Monitoring Mode

To place the Stripper Module controller in the Input monitoring mode, proceed as follows:

1. Turn “off” power to the terminator and the stripper controller.
2. Turn the system “on” and wait for the Stripper controller operator interface LEDs to be turned on.
3. With all LEDs on, press and hold the **Mode Select** button (see Figure 6) for two seconds after all the LEDs are turned off.
4. Release the **Mode Select** button and the Input monitoring function will be operative.

In this mode, the current state of the switches and inputs are displayed using the LEDs on the operator interface. The LEDs correspond to the inputs as designated below (Figure 11).

LED	INPUT/SWITCH
Strip and Crimp mode LED	Ready/Error Input
Crimp Only Mode LED	Tooling installed Switch
Strip Only Mode LED	Guard interlock Switch
Pullback Error LED	Pullback Switch
Transfer Error LED	Side Transfer Switch
Terminator Error LED	Terminator TDC Switch
Error LED	Tonk Switch
Wire Sensor LED	Wire Sensor Input
Footswitch LED	Footswitch Input

Figure 11

Press the **Mode Select** button to exit the diagnostics mode.

7. MECHANICAL ADJUSTMENTS

Most of the mechanical adjustments are made with adjustment screws containing (NYLON) locks. A 3mm wrench is required to make most adjustments.

NOTE

if the adjustment screws become loose, the NYLON locks can be tightened by turning the back-up setscrew clockwise.

DANGER

To avoid personal injury, be sure to disconnect power to the stripping module and terminator before making any adjustments.

7.1. Strip Blade Closure Adjustment (Figure 12)

The strip blades must be adjusted to a depth that will permit the cutting and stripping of the insulation slug from the conductor wires. This adjustment is made by turning the setscrew clockwise to strip a smaller wire and counterclockwise to strip a larger wire.

1. Turn power to the stripping module OFF.
2. Move the stripping assembly to the right side of the transfer assembly.
3. Pull the cam assembly forward using a 3mm hex wrench. (Blades should be in the “closed” position.)
4. Insert a stripped wire into the opening of the blade assembly.
5. Using the strip depth adjustment screw, adjust the blade closure until the blades drag on the conductor of the wire, then rotate the adjustment screw 1/4–turn counterclockwise. Rotate the adjustment screw clockwise to close the blades for smaller wire and counterclockwise to increase the blade opening for larger wire.
6. Remove the hex wrench before “powering up” the machine.

7.2. Strip Length Adjustment (Figure 12)

The wire strip length may vary between applicators and various terminals.

This adjustment is made with the adjustment screw located at the front of the stripping module. Turn the adjustment screw clockwise to increase the strip length or counterclockwise to decrease the strip length.

7.3. Wire Brush Adjustment (Figure 12)

1. Turn power to the stripping module OFF.
2. Slightly loosen the applicator latch.
3. Turn the wire brush adjustment screw clockwise to decrease the wire brush or counterclockwise to increase the wire brush.
4. Push the strip mechanism toward the rear of the machine until the adjustment screw hits the rear stop.
5. Tighten the applicator latch.

CAUTION

If the applicator latch is not fully tightened, the top portion of the strip subassembly may move, causing variations in the wire brush.

7.4. Gripper Adjustment

A. Jaw Height Adjustment

The jaw height adjustment is required to align the center of the wire to be stripped with the center of “V”-shaped opening in the outer strip blade.

1. Turn power to the stripping module OFF.
2. Place a wire onto the lower jaw (Figure 13) and insert the wire through the opening in the strip blades.
3. Center the wire in the center of the “V” opening in the outer blade by turning the jaw–height adjustment screw located on the top of the right gib of the grip sub–assembly. Turning the adjustment screw clockwise will lower the jaw. Turning the adjustment screw counterclockwise will raise the gripper jaw.

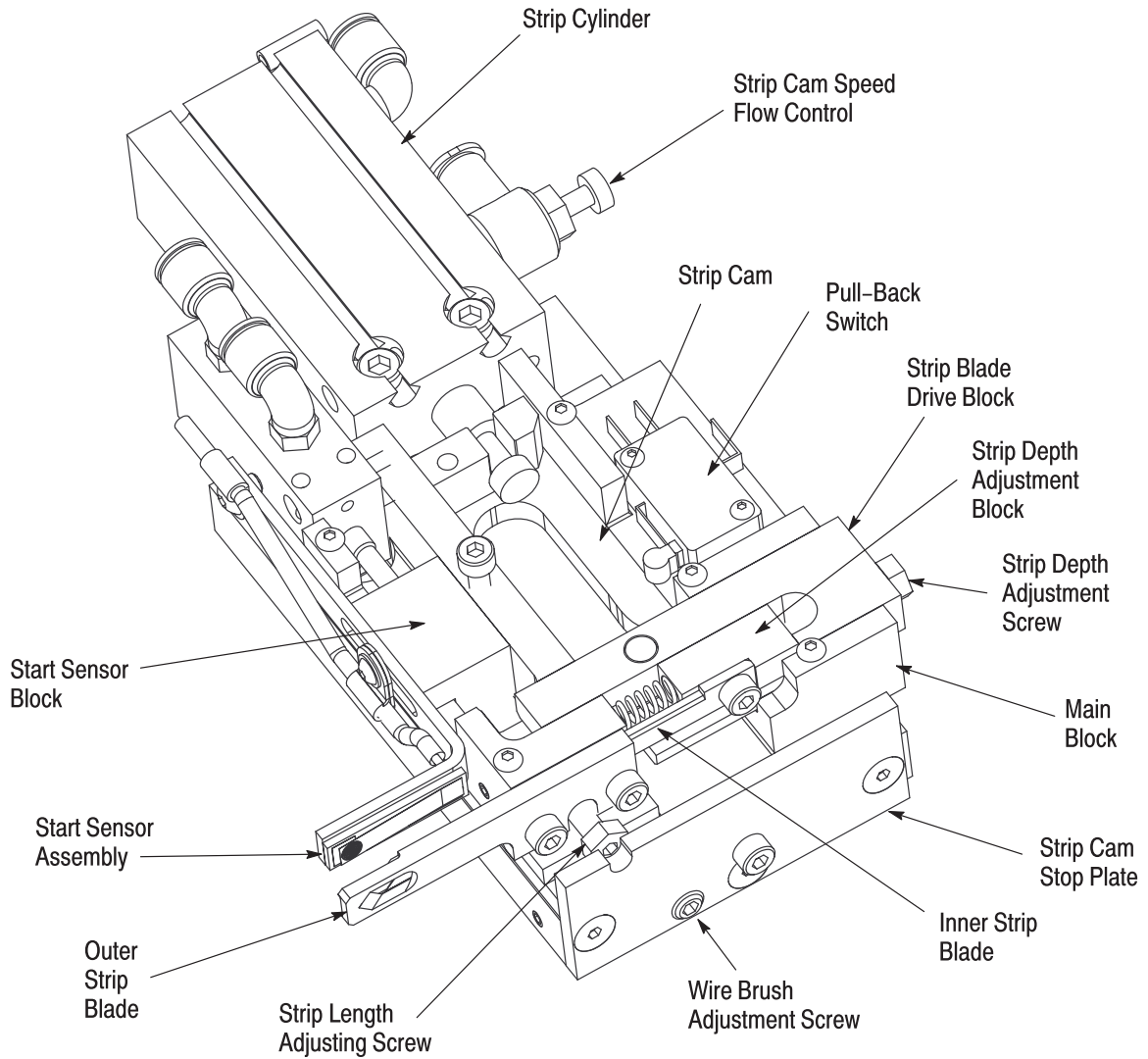

Stripping Subassembly

Figure 12

B. Gripper Pressure Adjustment

The gripper pressure adjustment may be necessary to prevent damage to the wire insulation.

To see the pressure level on the gage, enter the step mode while in strip and crimp mode or strip only mode. Perform the first step by pressing the step button. This will close the grip jaw and the pressure will be displayed on the gage next to the gripper pressure regulator (Figure 1).

- *Increase* the pressure by pulling the lock knob away from the machine and turning the knob *clockwise*. Push the lock knob back toward the machine after adjustment.
- *Decrease* the pressure by pulling the lock knob away from the machine and turning the knob *counterclockwise*. Push the lock knob back toward the machine after adjustment.

CAUTION

If the pressure is set too low, the wire may be pulled through the grip jaws during the pull back motion causing wire damage. If this occurs, increase the gripper pressure until the insulation is pulled off the wire properly.

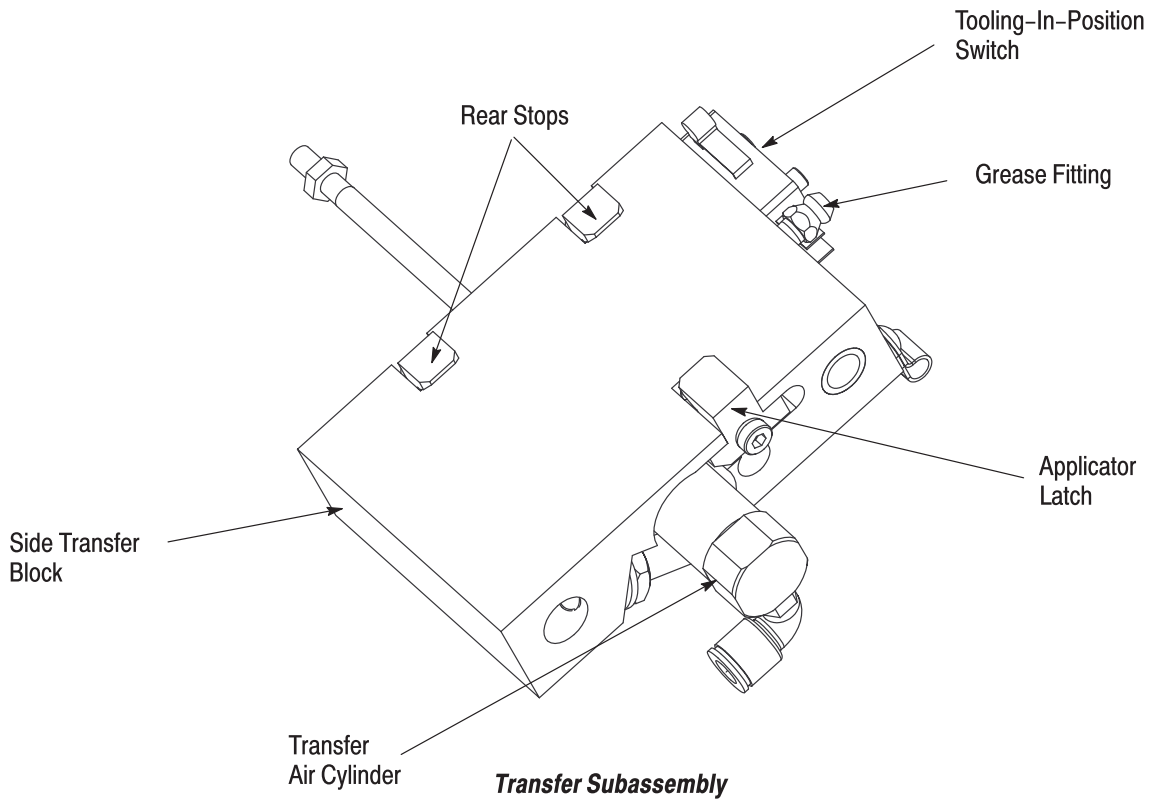
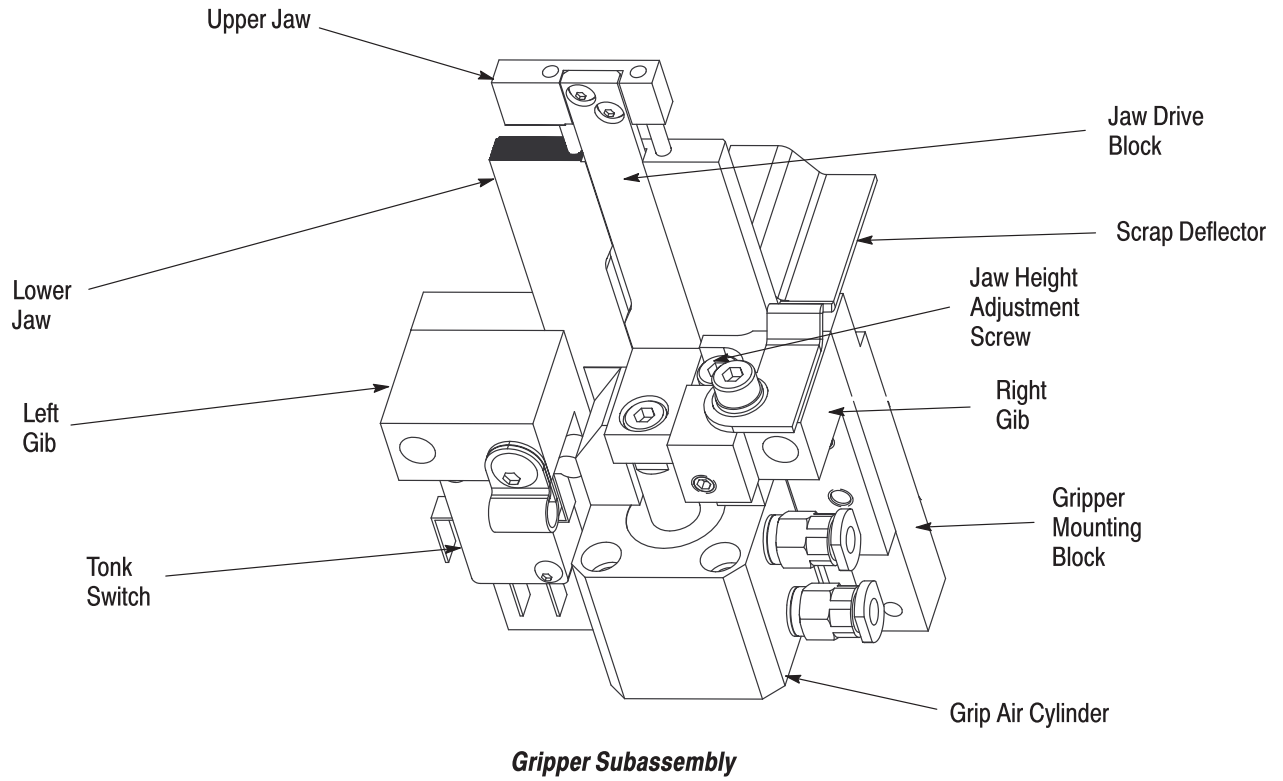

Figure 13

7.5. Tonk Adjustment

The tonk adjustment is required to make sure that the wire is level between the terminal and gripper jaws during the crimping operation.

1. Turn power to the stripping module OFF.
2. Open the main guard.
3. Push the transfer sub-assembly (Figure 13) along with the stripping subassembly (Figure 12) to the right-side position.
4. Insert a pre-stripped wire through the gripper jaws into the approximate location required for wire stripping.
5. Manually close the upper gripper jaw onto the wire.
6. Remove the protective cover from the motor on the terminator. Then use a hex wrench to lower the machine ram until it is at its lowest point.
7. Make sure the wire is sitting in the terminal crimp barrel.
8. If the wire is not in the correct position, *loosen* the T-handle on the tonk block (Figure 3) and turn the tonk adjustment screw clockwise to lower the wire; turn the adjustment screw counterclockwise to raise the wire.
9. Tighten the T-handle on the tonk block.
10. Return the terminator ram to the top position and re-install the protective cover at the rear of the terminator motor.

7.6. Strip Cam Speed Adjustment (Figure 12)

The strip cam speed may need to be adjusted (slowed) if the gripper pressure is lowered enough to slow the grip cylinder.

Adjust the strip cylinder speed by turning the flow control knob on the side of the strip air cylinder. Turn the knob clockwise to slow the cylinder speed; turn the knob counterclockwise to increase the cylinder speed.

7.7. Start Sensor Gap Adjustment

If the start sensor lever gap becomes too small, the start sensor may not operate properly. Errors (such as *Error 13 — Wire sensor is bad or stuck in the “down” position*) may occur. Refer to Figure 10 for a listing of errors.

Using the set screw on the back side of the start sensor assembly, adjust the start sensor lever gap to achieve a .25mm [.010 in.] gap between the printed circuit board and the lever. See Figure 14.

Turn the set screw clockwise to increase the gap; counterclockwise to decrease the gap.

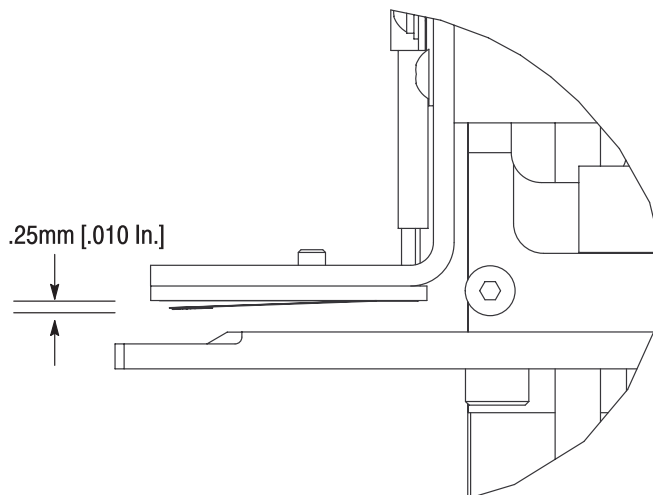

Figure 14

8. ELECTRICAL ASSEMBLY

Refer to the electrical assembly drawings shipped with the machine.

9. PARTS REPLACEMENT

9.1. Strip Blade Replacement (Figure 15)

DANGER

To avoid personal injury, be sure to disconnect power to the stripping module and terminator before replacing strip blades.

1. Turn power to the stripping module OFF.
2. Loosen the screws securing the scrap covers. Then slide the scrap covers off.
3. Remove the outer blade by removing the two screws securing the blade to the main block.
4. Remove the inner blade by removing the single screw securing the blade to the blade adjustment block.
5. Install new blades (replacement is in reverse order of removal).
6. Check the strip depth after removing/replacing the blades. Adjustment may be required.

9.2. Start Sensor Assembly Replacement (Figure 15)

DANGER

To avoid personal injury, be sure to disconnect power to the stripping module and terminator before replacing the start sensor.

1. Turn power to the stripping module OFF.
2. Remove the cable clamp from the rear of the strip cylinder.
3. Remove the three screws securing the start sensor assembly to the start sensor block.
4. Install the new start sensor assembly onto the start sensor block by installing the two outer screws into the block and *loosely* tightening them.
5. Turn the strip length screw (Figure 12) clockwise until the main block is 10.16 [.400] from the strip cam stop plate. See Figure 16.
6. Adjust the start sensor arm so that the lever is 4.78 [.188] from the back of cutting surface of the outer strip cam.

NOTE

When adjusting the outer strip arm, be sure that the start sensor block is pushed forward against the strip length adjustment screw.

7. Adjust the height of the start sensor so that the lever is centered in the opening of the outer strip blade.
8. Fully tighten two screws securing the start sensor assembly to the start sensor block.
9. Install the middle screw through the wire clamp and start sensor arm and into the start sensor block. Fully tighten the middle screw.
10. Install the wire clamp onto the strip air cylinder with the new start sensor assembly wire passing through the clamp.

NOTE

Be sure that a loop of wire exists between the wire clamp on the back of the strip air cylinder and the start sensor arm when the arm is located all the way forward.

9.3. Recommended Spare Parts

- Auto Sensor
- Stripping Blades – Front Blade, Rear Blade

10. REVISION SUMMARY

New release of 417-11 per EC 0990-1568-04. This document supercedes 409-10054.

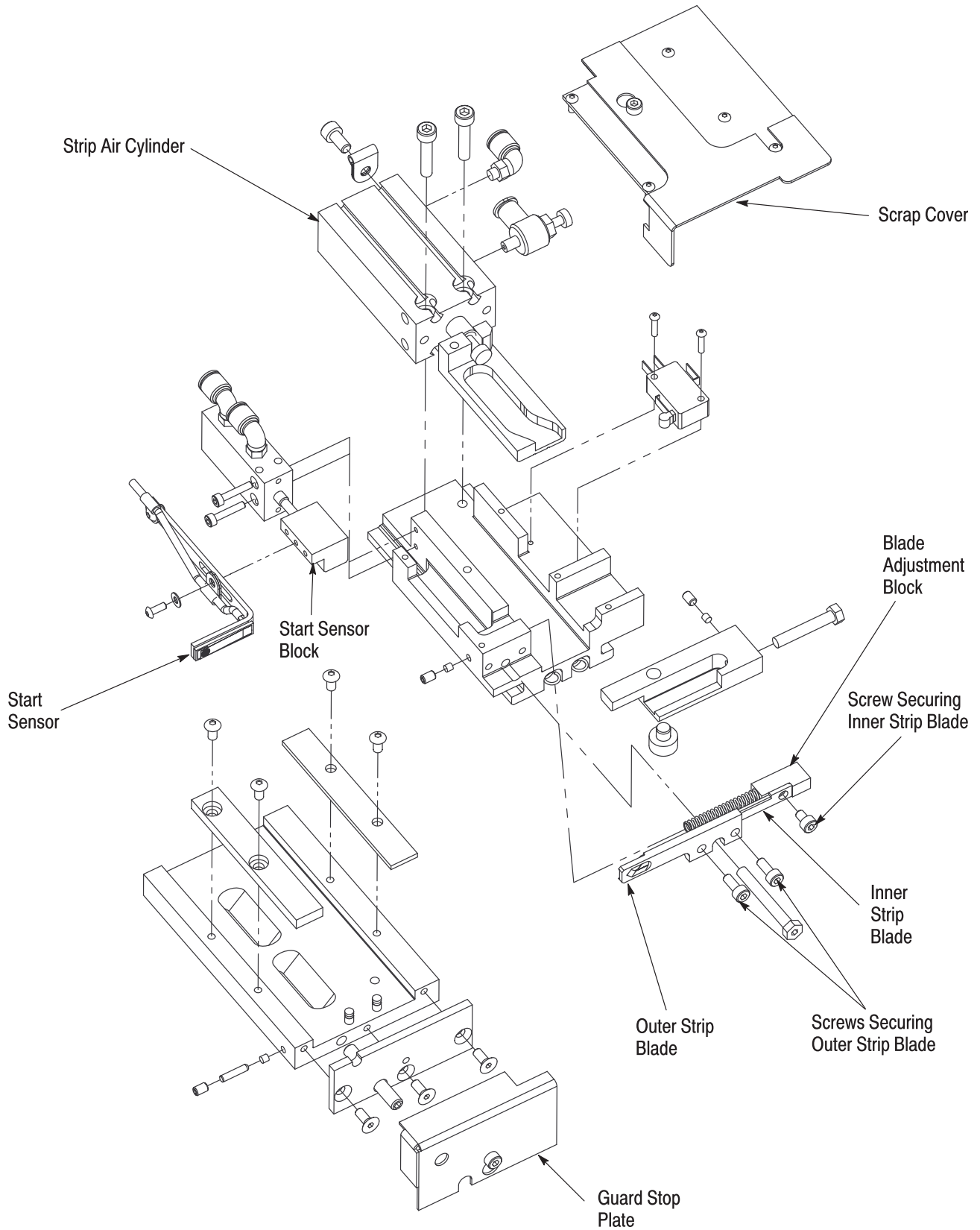

Figure 15

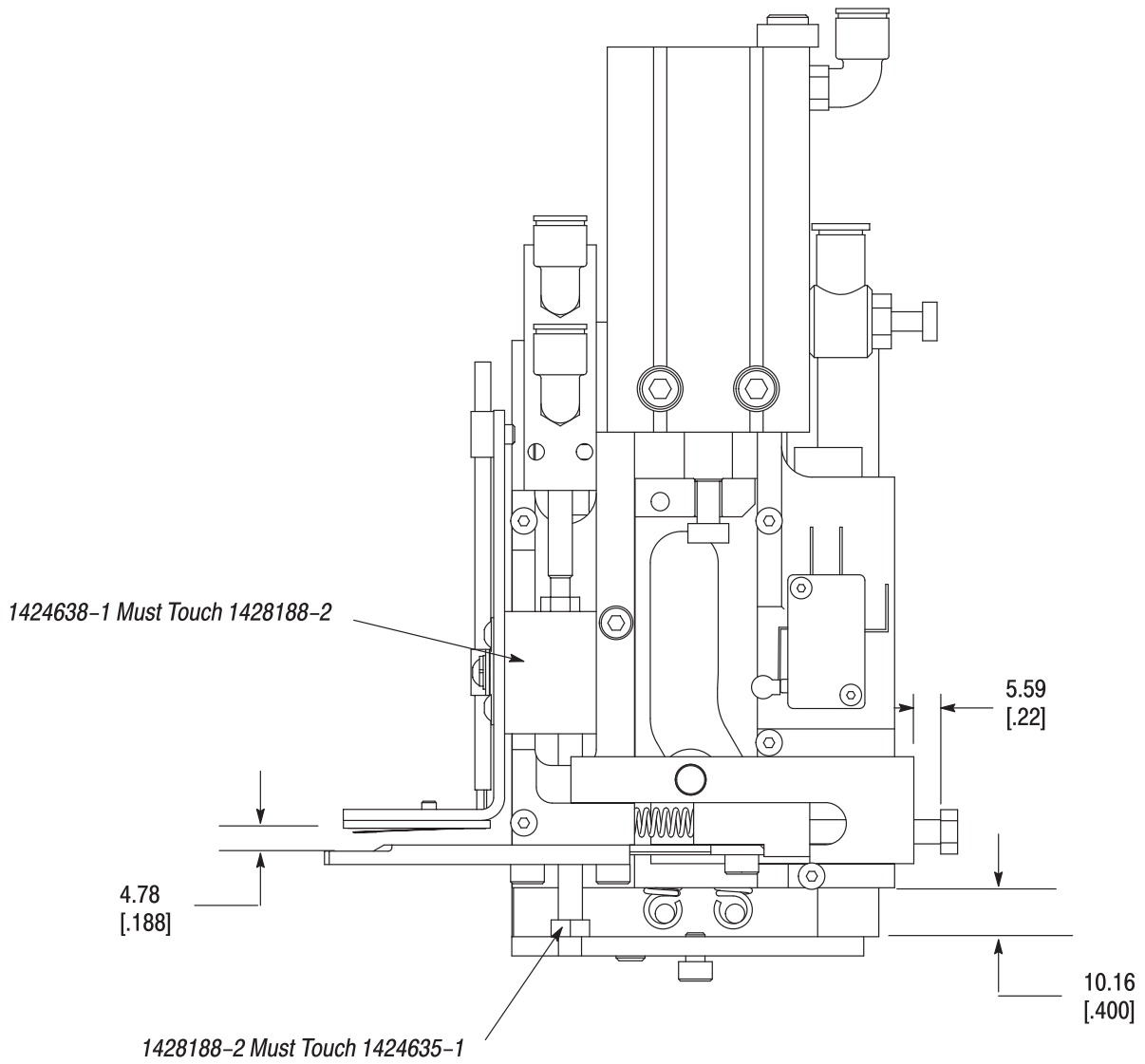

Figure 16