



customer manual

SAFETY PRECAUTIONS	READ THIS FIRST !	2
1. INTRODUCTION		3
2. DESCRIPTION		4
2.1. Physical Description		4
2.2. Electrical Description		5
2.3. Guards		8
3. RECEIVING INSPECTION AND INSTALLATION		9
3.1. Receiving Inspection		9
3.2. Installation		9
3.3. Considerations Affecting Machine Placement		10
4. OPERATION		11
4.1. Applicator Installation		11
4.2. Setup		15
4.3. Mode Selection		15
4.4. Crimp Height Adjustment Feature		18
4.5. End-Feed/Side-Feed Conversion		18
5. PREVENTIVE MAINTENANCE		18
5.1. Cleaning		18
5.2. Lubrication		18
6. ADJUSTMENTS		19
6.1. Measuring and Adjusting the Shut Height		19
6.2. Crimp Height Adjustment		20
6.3. Guard Insert Adjustment		23
6.4. Drive Belt Tension Adjustment		24
6.5. Light Bulb Replacement		26
7. TROUBLESHOOTING		27
8. REVISION SUMMARY		33

CUSTOMER SERVICE CENTER**CALL TOLL FREE 1-877-671-2955**

The **ATS Customer Service Center** offers a means of providing technical assistance when required.

In addition, Field Service Engineers are available to provide assistance in the adjustment or repair of the application equipment when problems arise which your maintenance personnel are unable to correct.

DANGER**SAFETY PRECAUTIONS AVOID INJURY**

Safeguards are designed into this application equipment to protect operators and maintenance personnel from most hazards during equipment operation. However, certain safety precautions must be taken by the operator and repair personnel to avoid personal injury, as well as damage to the equipment. For best results, application equipment must be operated in a dry, dust-free environment. Do not operate equipment in a gaseous or hazardous environment.

Carefully observe the following safety precautions before and during operation of the equipment:

- ALWAYS wear appropriate ear protection.
- ALWAYS wear approved eye protection when operating powered equipment.
- ALWAYS keep guard(s) in place during normal operation.
- ALWAYS insert power plug into a properly grounded receptacle to avoid electrical shock.
- ALWAYS turn off the main power switch and disconnect electrical cord from the power source when performing maintenance on the equipment.
- NEVER wear loose clothing or jewelry that may catch in moving parts of the application equipment.
- NEVER insert hands into installed application equipment.
- NEVER alter, modify, or misuse the application equipment.

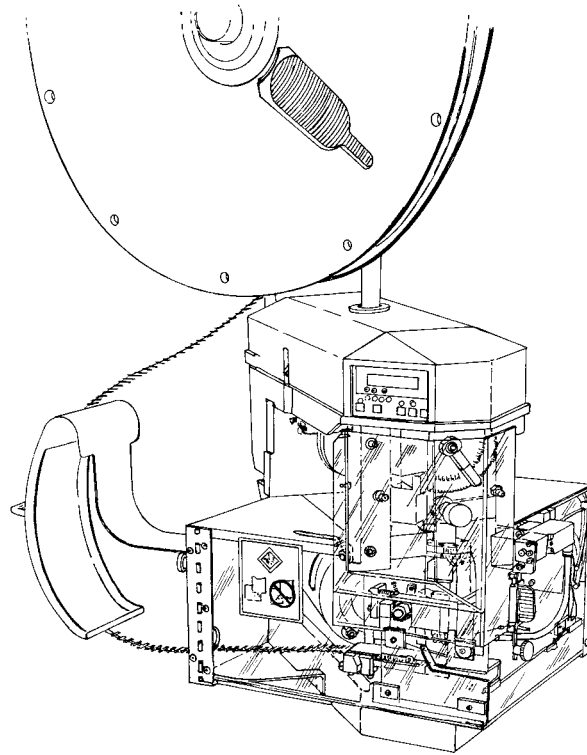

T-5000 SERIES	PART NUMBER	TERMINATING MACHINE DESCRIPTION
T-5000	354500-1	Machine with Manual Crimp Height Adjustment
TSM-5000	354500-9	Machine with Manual Crimp Height Adjustment (Including Sensors for Crimp Quality Monitor)
TSA-5000	1-354500-1	Machine with Automatic Crimp Height Adjustment (Including Sensors for Crimp Quality Monitor)

Figure 1

1. INTRODUCTION

This manual contains information on operation, preventive maintenance, and adjustments of the T-5000 Series Terminating Machines shown in Figure 1.

Figure 2 contains T-5000 Series Terminating Machine specifications and requirements.

Stroke:	1 5/8 in.
Capacity:	22,241 Newtons [5000 lb.] Maximum Crimp Force
Deflection:	.076 mm [.003 in.] Maximum per 4448 Newtons [1000 lb.] Crimp Force
Noise:	76dB Typical at Operator Position with Standard Mechanical Feed Applicator
Weight:	Approximately 109 kg [240 lb.]
Air:	620-760 kPa [90-100 psi], 2.83 liters/sec (6 scfm) (When required for use with air-feed applicators)
Height:	508 mm [20 In.]
Electrical:	100-220 Vac, 50/60 Hz, single phase, 6A, with ground
Temperature:	Ambient operating temperature range of 5° to 40° C [41° to 104° F]
Relative Humidity:	Relative humidity range of 20 to 95 percent (noncondensing)

Figure 2

When reading this manual, pay particular attention to **DANGER**, **CAUTION**, and **NOTE** statements.

DANGER Denotes an imminent hazard which may result in moderate or severe injury.

CAUTION Denotes a condition which may result in product or equipment damage.

NOTE Highlights special or important information.

2. DESCRIPTION

The T-5000 Series Terminating Machine was designed to be used as a stand-alone semi-automatic bench machine. It is assembled with metric hardware.

NOTE Measurements are in metric units [followed by U.S. customary units in brackets]. Some commercial items may contain non-metric hardware.

The T-5000 Series Terminating Machine accepts a wide variety of miniature quick-change type (mini) applicators, thus providing a great selection of terminals for many applications. Some applicators may require a change of feed cam to operate with this 1 5/8-inch stroke terminating machine.

End-feed and side-feed mini applicators are easily installed and removed without repositioning the applicator mounting plate on the machine. A precision adjustment feature is included in the terminating machine to provide quick and accurate crimp height adjustments.

The following options are available for the T-5000 Series Terminating Machine:

Available Option	Part Number	Purpose
Air Feed Assembly	354578-1	The optional air feed assembly is required to run air-feed applicators.
Guard Inserts	(Figure 19)	Guard inserts are used for certain strip-fed and tape-fed product.
Lubricator Bowl Assembly	354550-1	The lubricator bowl assembly is required to pre-lubricate strip-fed product.
Lift Eye	354577-1	The lift eye facilitates the lifting of the machine during installation.
Crimp Quality Monitor (CQM) Assembly	1320420-2	The CQM monitors crimp height.
CQM Interface Kit	1320431-2	The interface is required to connect the CQM to the terminating machine.
CQM Adapter	122990-9	The CQM adapter is used for adding CQM sensors to T-5000 Terminating Machine.

2.1. Physical Description

The T-5000 Series Terminating Machine provides the force required to crimp terminals in an applicator. A terminal is attached to the wire by placing the wire in the crimp area and pressing the foot switch. The machine consists of four functional areas.

- The **motor-pulley group** includes an ac motor which drives a pulley by a toothed belt. The motor is activated each cycle and rotates the crankshaft either one half or one full revolution, depending on the full/split-cycle setting.
- The **crankshaft-ram group** covers the motor pulley's rotational force to the up-and-down action of the ram for driving the applicator during the crimping cycle.
- The **base plate** provides the mounting surface on which the applicator is installed. The quick-release latching feature permits fast, easy installation and removal of the applicator.
- A crimp height adjustment group uses an eccentric located in the ram linkage, along with detented stops in the mechanism to adjust the crimp height. T-5000 and TSM-5000 machines contain a **manual precision adjustment lever** (Figure 17), while the TSA-5000 machine contains an **automatic precision adjustment (auto adjust) feature** (Figure 18). Indexing the mechanism in either direction will change the crimp height in increments of approximately 0.013 mm [.0005 in.] per step.

NOTE

The Crimp Quality Monitor is required to use the automatic precision adjustment (auto adjust) feature. Refer to the options listed on the previous page.

2.2. Electrical Description

The T-5000 Series Terminating Machine electrical components consist of the operator control panel, the motor, and the CPU/motor controller package. The machine will automatically detect the supply voltage and adjust the controller accordingly. A main power switch/circuit breaker is located on the top left side of the machine. This switch connects ac power to the control system.

The operator control panel (Figure 3) is mounted to the machine frame under the front corner and is visible through the top cover. The control panel consists of a 16-character display and five buttons marked with icons depicting each function. The display shows total machine cycles and a batch count.

DANGER

The CPU/motor controller package contains high voltages which can remain even after power has been removed. See Section 7 for precautionary measures to follow if internal access is required.

The CPU/motor controller is located under the top cover of the machine. It is a modular unit that contains all of the electronics necessary to operate the machine.

There are four CPC connectors located on the electrical control box. See Figure 4. The interface connection to the Crimp Quality Monitor, connector J1, is located on the left side of the machine just below the top cover. The remaining three are located along the right side of the machine just below the top cover. Starting at the front of the machine are connections for; the terminating machine interface (J2), foot switch (J4), and main drive motor (J5), and the power cord.

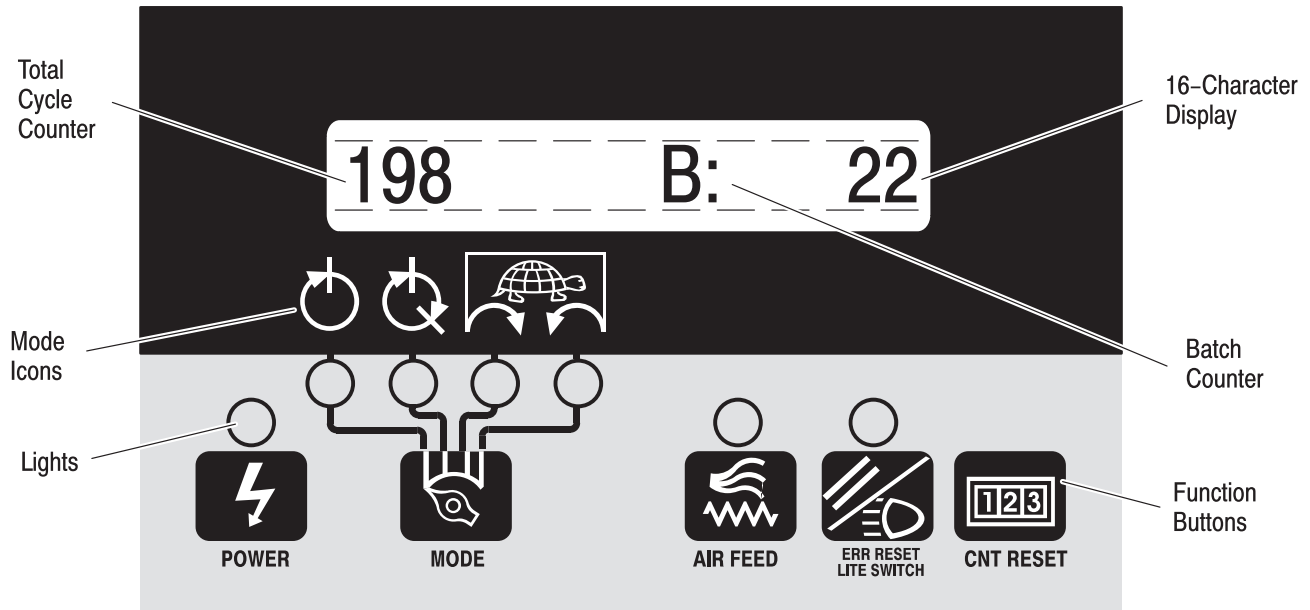

FUNCTION BUTTONS



POWER

Allows the controller to provide power to the motor.



MODE

Selects the current mode of operation by stepping through the four choices indicated.



AIR FEED

Manually activates the optional air feed valve. Press once to turn "on," press again to turn "off."



ERROR RESET/LIGHT SWITCH

Resets the control unit after an error was encountered. Toggles the work light on or off while no error message is displayed.



COUNTER RESET

Resets the batch counter in the display.

Figure 3

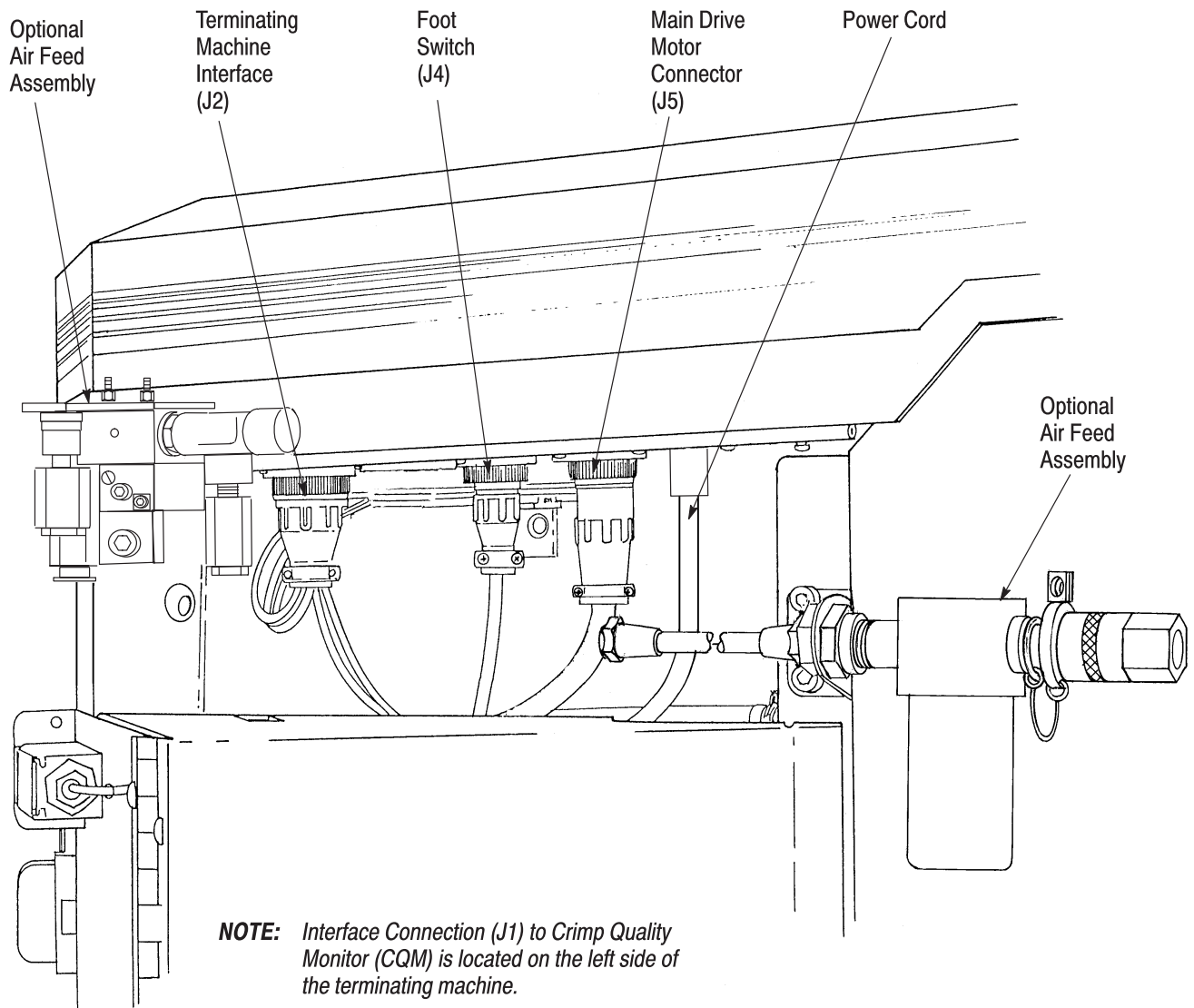

Figure 4

A work light is provided to light the target area of the applicator. See Figure 5.

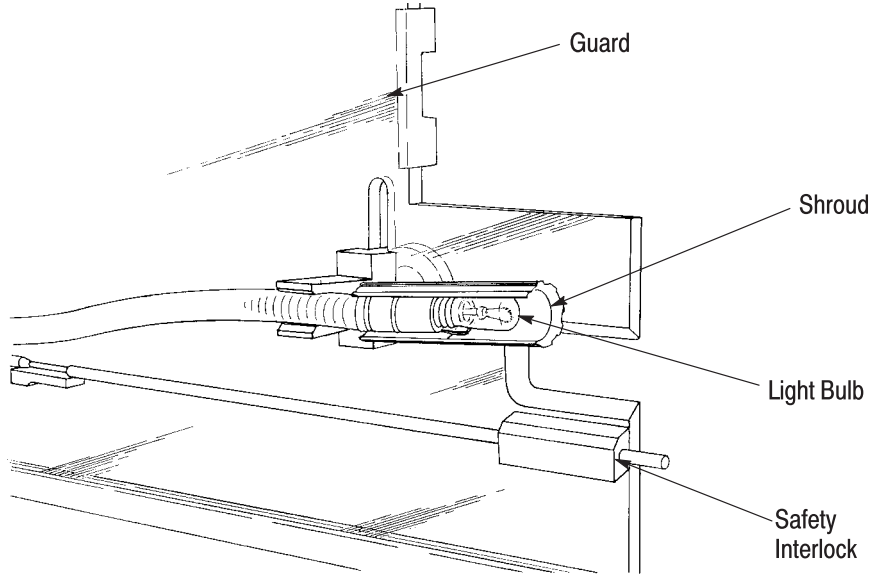

Figure 5

2.3. Guards

Guards are installed to provide protection for the operator while maintaining proper visibility of the work area. The guards swing open to allow easy access for applicator installation and setup. Safety interlocks on the guards prevent machines from cycling if the guard doors are open during production operation.

In addition, the machines contain interlocks at the guard insert that prevent full-cycle and split-cycle production operation if the guard insert is removed. See Figure 6.

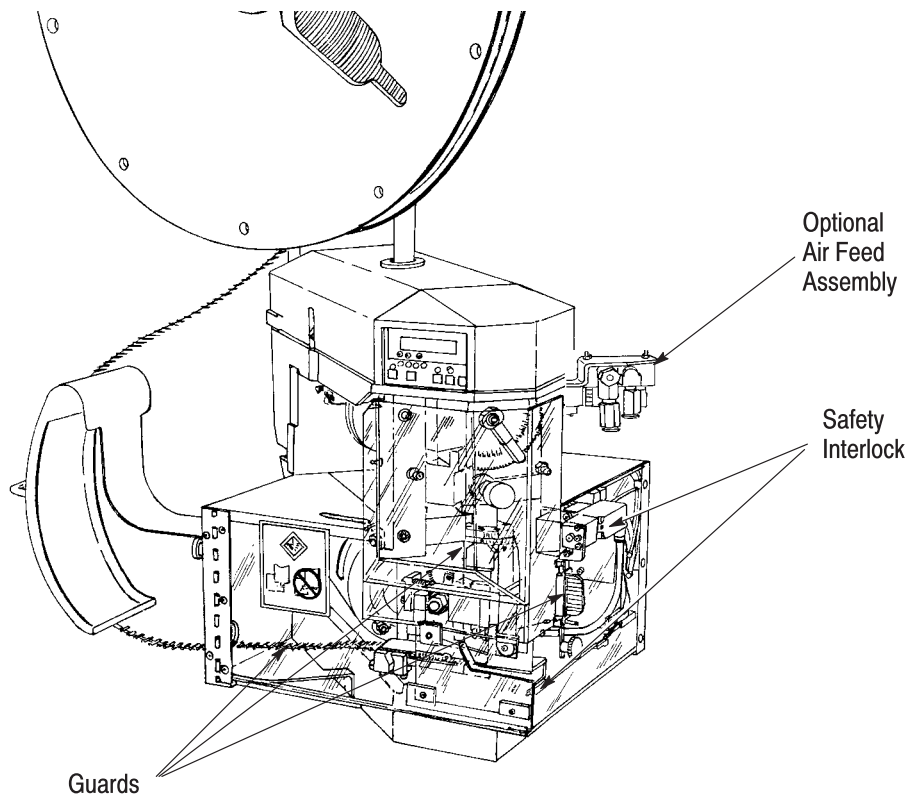

Figure 6

3. RECEIVING/INSPECTION, AND INSTALLATION

3.1. Receiving/Inspection

T-5000 Series Terminating Machines are thoroughly inspected during and after assembly. A final series of inspections is made to insure the proper machine functioning before packaging and shipping.

However, damage may occur during shipment. Remove the machine from the crate, as described in Paragraph 3.2, and carefully inspect the machine for damage. If damage is evident, file a claim against the carrier and notify ATS immediately.

3.2. Installation

DANGER

The T-5000 Series Terminating Machine is heavy. To avoid personal injury, do not attempt to lift the machine by hand.

Place the T-5000 Series Terminating Machine crate onto a bench or work area. Remove all mounting bolts securing the terminating machine to the shipping pallet.

NOTE

Optional Lift Eye 354577-1 (Figure 7) is recommended for use when hoisting the machine. These instructions reflect the use of this accessory.

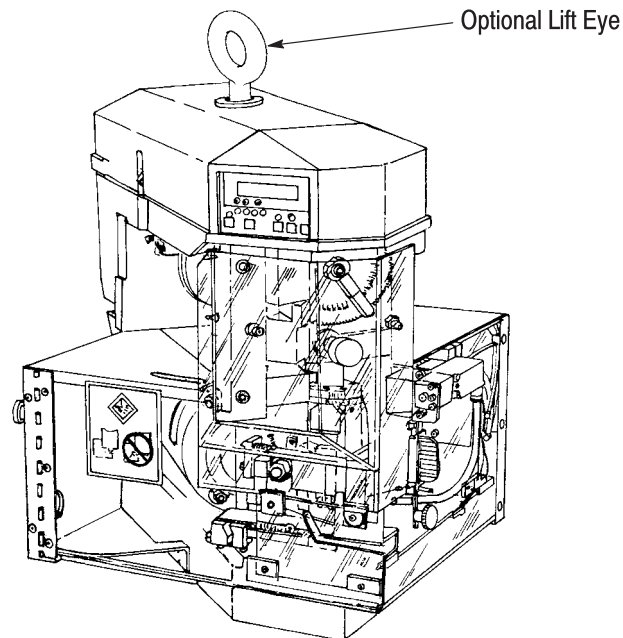

Figure 7

CAUTION

*If the optional lift eye is used, install it **carefully**. A 19.05-mm [.75-in.] thread length engagement is required for the lift eye to support the machine, which weighs approximately 109 kg [240 lb]. Be sure the locking screw for the reel support is backed out, in order to achieve the 19.05-mm [.75-in.] thread length engagement required to lift the machine.*

*If using a lift eye other than 354577-1, be sure it is a .75-in x 10 UNC-2A lift eye. **The crankshaft may be damaged if lift eye is threaded more than 25.4 mm [1.00 in.] into the machine.***

Attach a suitable hoist to the optional lift eye, lift the machine, and place it in the selected operating location. After the machine is in its final position, remove the lift eye and replace it with the reel mounting support.

CAUTION

Do not attempt to cycle the terminating machine with the lift eye in place. Damage to the machine could occur if the lift-eye is not removed prior to operation.

Insert the reel support post into the hole in the top of the machine and turn the post clockwise until the threads begin to bottom out. Then turn the post counterclockwise until the flat on the threaded portion of the reel

support is aligned with the locking screw. Tighten the screw. Attach the reel support arm to the reel post. Be sure to align the tabs on the reel support arm with the slots in the end of the reel support post. The adjusting screw should be to the right side (while facing the machine) of the horizontal bar on the support post. Secure the reel support arm to the post by inserting the locking pin into the hole in the support post.

Attach the terminal strip guide included with the machine with the two thumbscrews supplied. Mount the guide on the left rear guard for side-feed applicators. Mount the guide on the right rear guard for end-feed applicators.

NOTE *When mounting the terminal strip guide for end-feed product, be sure to use the upper set of mounting holes.*

Connect the foot switch to connector J4 of the machine. Refer to Figure 4.

Connect the power cord to a suitable electrical supply and machine.

NOTE *The machine will automatically detect the supply voltage and adjust the controller accordingly.*

3.3. Considerations Affecting Placement of Bench Machines

The location of the machine in relation to the operator's position is extremely important in terms of both safety and maximum efficiency. Studies have repeatedly shown that operator fatigue will be reduced, and greater efficiency achieved, if: (1) the bench is of appropriate height, preferably with sound-deadening rubber mounts; (2) the machine is properly located on the bench with ample work areas on both sides to facilitate work flow; (3) the operator uses a swivel chair with padded seat and back rest which are independently adjustable; and (4) the foot switch, on machines so equipped, is placed on a rubber mat to maintain its movability, while preventing it from sliding unintentionally. Figure 8 illustrates proper machine location and operator position. Figure 9 provides a typical materials location / plan layout.

1. Bench

The bench to be used should be of sturdy construction, preferably with rubber mounts to minimize noise. A height of 762.0 mm to 812.8 mm [30 in. to 32 in.] is the most suitable for operator comfort and convenience. This height allows the operator to rest both feet on the floor, thereby providing for the shifting of weight and leg position.

2. Machine Location on Bench

The machine should be located near the front of the bench with the "target area" (tooling area where the product is applied) not more than 152.4 mm to 203.2 mm [6 in. to 8 in.] from the front edge. This location will eliminate unnecessary operator motion and help to avoid back strain and fatigue.

Orientation of the machine should be such that the "target area" is facing the front of the bench and is parallel to the front edge. (Access to the back of the machine MUST also be provided.)

NOTE *Machines have provisions for being bolted to the bench.*

3. Operator's Chair

The operator's chair should swivel, and should have independent seat height and back rest adjustments. The seat and back rest should be padded, and the back rest should be large enough to provide support both above and below the waist line.

In use, the chair should be far enough under the bench so that the operator's back is straight and is supported by the back rest.

4. Foot Switch

When the operator is correctly positioned in front of a machine equipped with a foot switch, the foot should rest on the switch comfortably. The foot switch should be movable, so that its location can be readily changed when the operator shifts position to minimize fatigue. Placing the switch on a rubber mat keeps it movable while preventing unintentional sliding.

The preferred foot switch location varies to some extent among operators. Some operators prefer the switch located so that their foot rests on the switch when their feet are in the natural sitting position (calf of leg perpendicular to the foot). Others prefer the leg to be slightly in front of the natural position. The important thing to remember is that the foot should be at approximately 90° (right angle) to the calf when resting on the switch. Those operators who prefer the foot switch slightly in front of the natural position may require a wedge-shaped block placed under it.



Figure 8

Materials Locations — Plan View

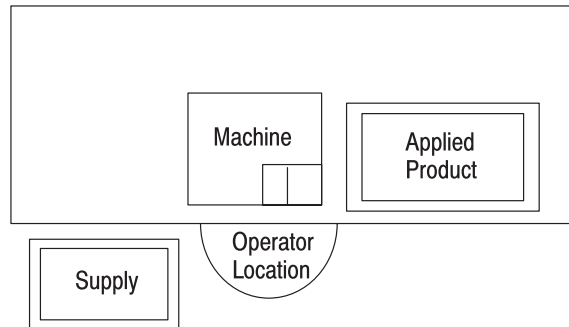

Figure 9

5. Scrap Removal

A suggested method of scrap removal: place a tray on the right side of the machine, under the cast slot in the frame, to capture the scrap chips. See Figure 16.

4. OPERATION

4.1. Applicator Installation

Install the proper applicator in the quick-change mounting base.

CAUTION

On T-5000 machines and TSM-5000 machines, be sure that the precision adjustment lever has returned to the “0” position before installing the applicator. On TSA-5000 machines, be sure that the indicator plate has been returned to the “0” position before installing the applicator.

In addition, be sure the applicator contains the proper feed cam prior to installation.

1. Loosen the T-handle and slide the applicator base clamp down. See Figure 10.

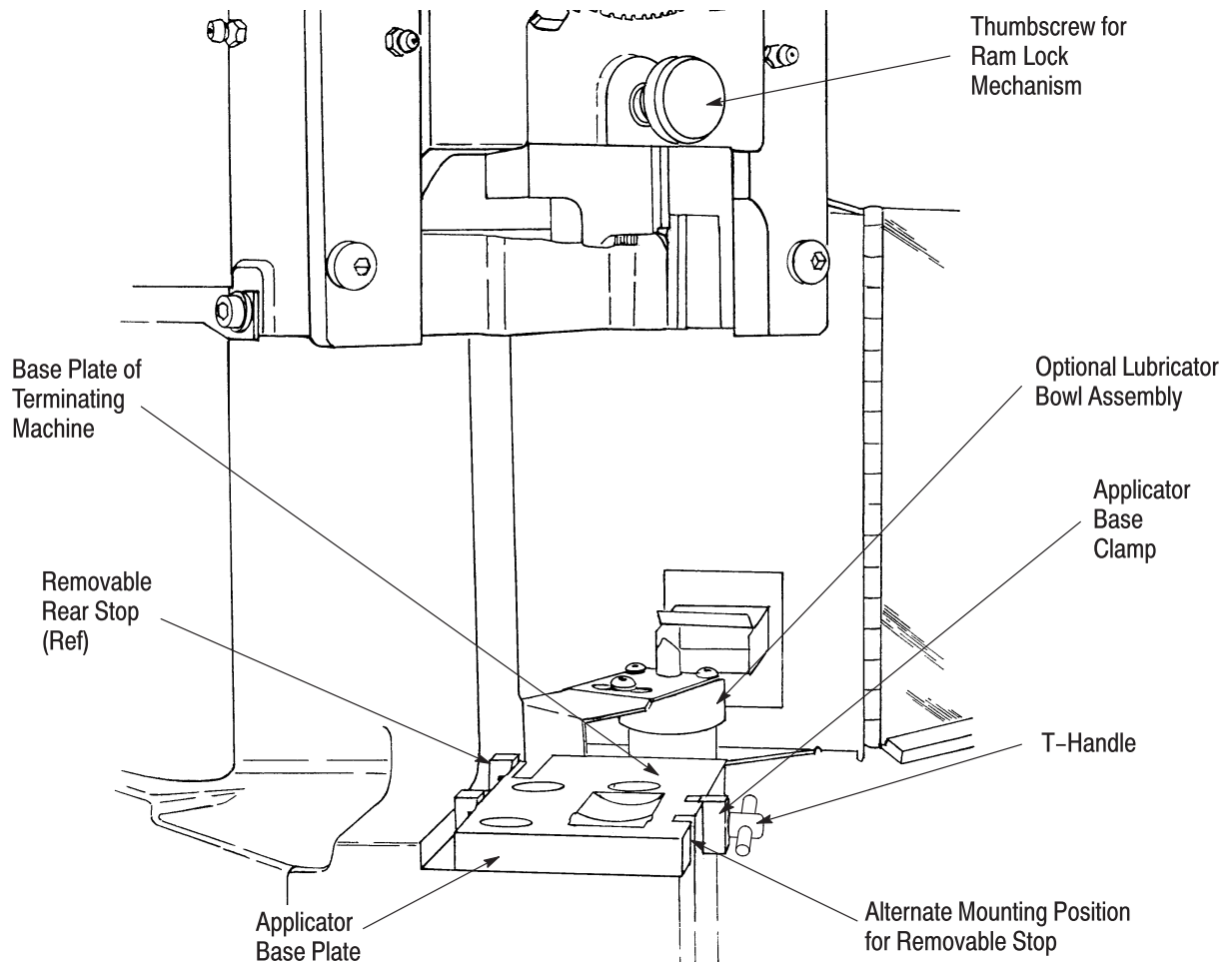

Figure 10

2. Lower the applicator ram lock mechanism by loosening the thumbscrew at the front of the ram assembly.
3. Place the applicator on the quick-change base plate, then slide it back until the two notches in the applicator base engage the stops at the back of the quick-change base plate. At the same time, guide the ram post into the ram post adapter, making sure the applicator ram engages the ram lock.
4. Slide the applicator base clamp UP and re-tighten the T-handle to secure the applicator in place.

NOTE

For some applicators, it may be necessary to re-configure the base plate by removing the T-handle, the applicator base clamp, and the removable rear stop located on the right side of the base plate. Re-install the rear stop at the alternate mounting position on the base plate. See Figure 10.

5. Set the crimp height and insulation crimp discs (if applicable) to the proper settings.
6. Secure the applicator ram post to the ram post adapter by turning the thumbscrew located at the front of the ram assembly clockwise until tight. See Figure 11.
7. If the applicator is an air-feed type, connect the airlines to the valves located on the right side of the machine. See Figure 12.

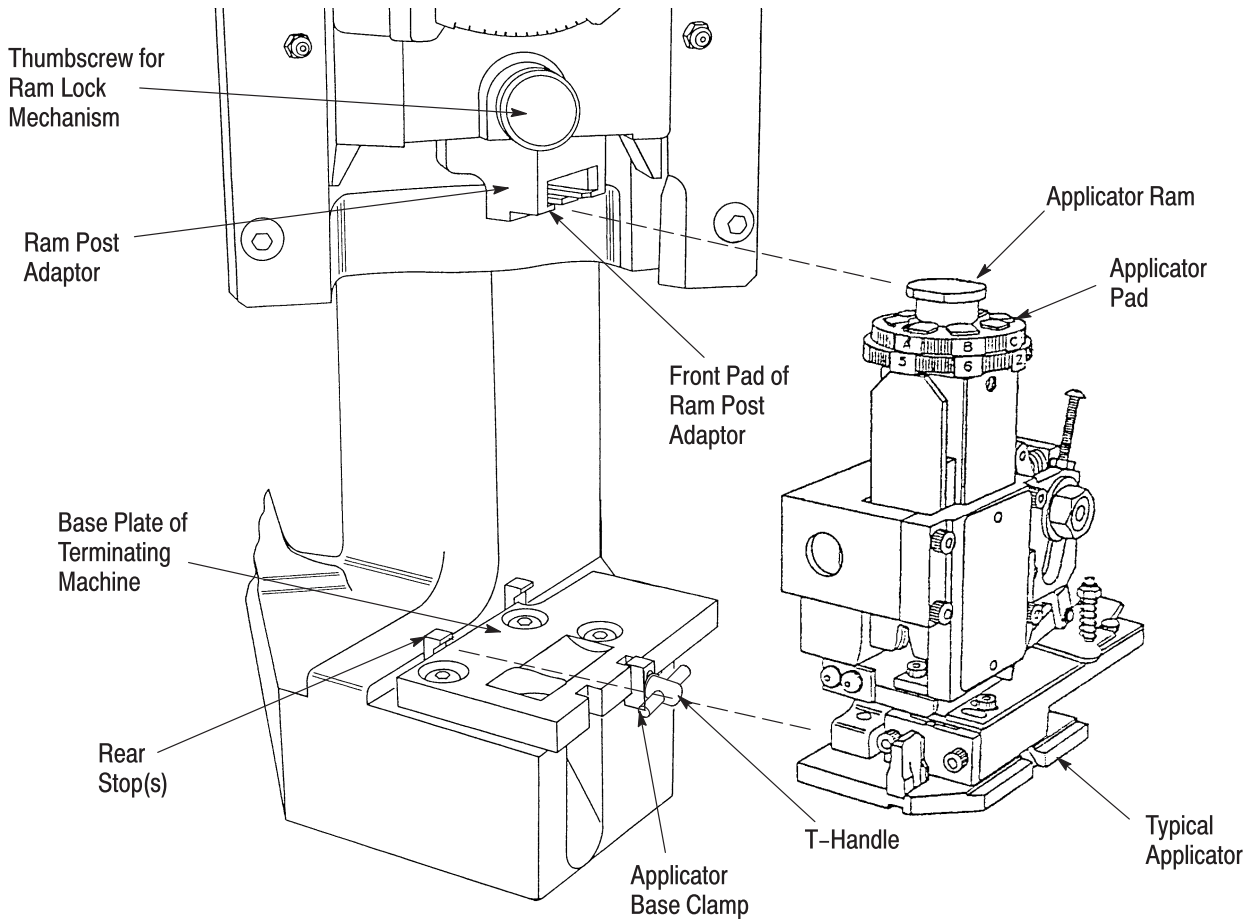

Figure 11

8. Adjust the reel support for side-feed or end-feed product, depending on the applicator being used.
9. Mount the terminal strip guide on the left rear sheet metal guard for side-feed product, or on the right rear sheet metal guard for end-feed product, depending on the applicator being used.
10. Mount the terminal reel on the reel support. Thread the terminal strip through the guard and into the applicator according to the instructions included with the applicator. Adjust the lubricator bowl (if applicable).
11. Align the reel brake to lead into the applicator.
12. On end-feed applicators, adjust the lead-in tube so that the terminal strip enters the strip guide of the applicator without bending or stressing the terminal strip.
13. Adjust the work light for proper lighting of the crimp area of the applicator by loosening the work light thumbscrew and sliding the light up or down as desired. Tighten the thumbscrew.
14. Close the guards by positioning the right guard next to the applicator. Lift the latch handle on the left guard and close, making sure that the interlock tabs on the left guard mate with the interlock switch on the right guard. Lower the latch handle to secure the guard doors. See Figure 13.

NOTE

The guard doors must be closed in order to operate the terminating machine.

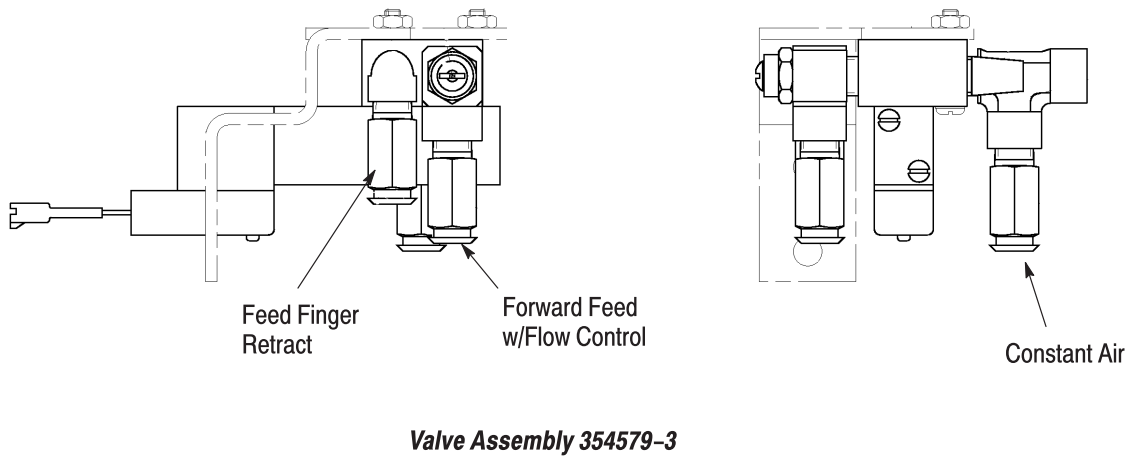
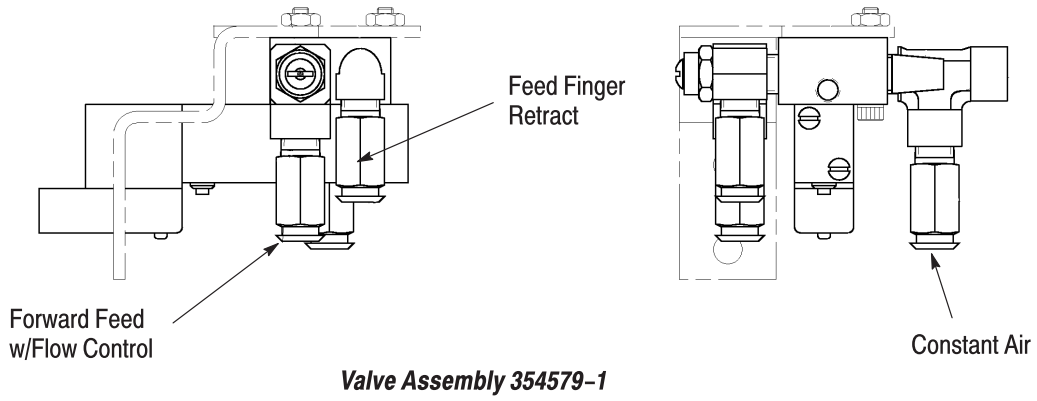

Figure 12

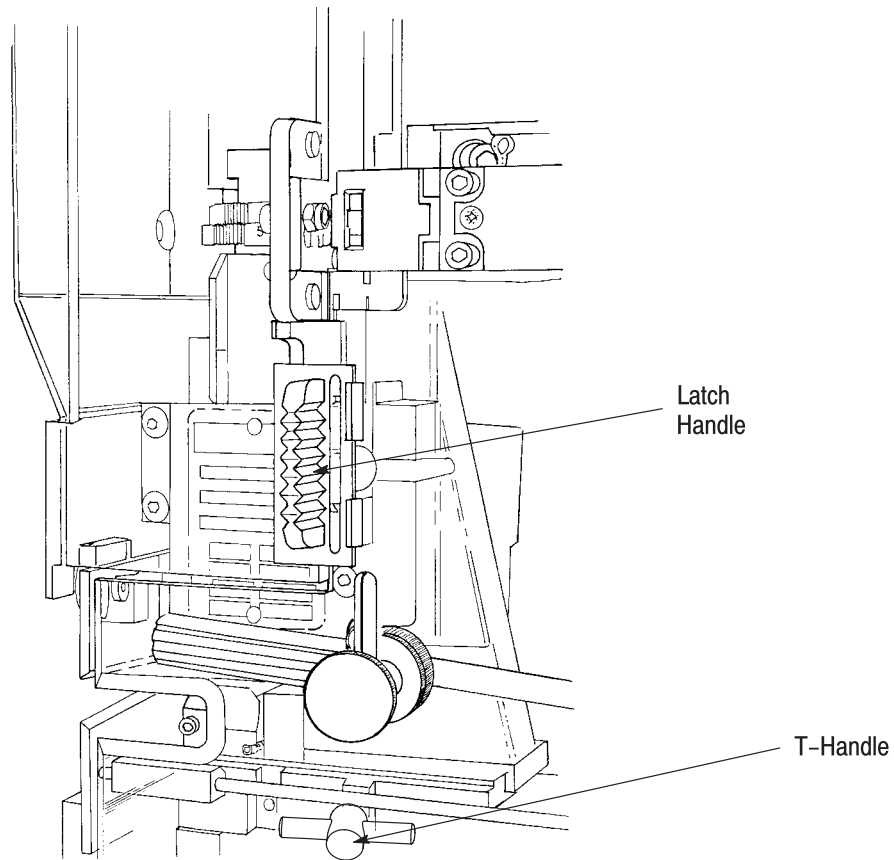

Figure 13

4.2. Setup

Install a mini applicator and terminals according to Paragraph 4.1, Applicator Installation.

1. Turn on the main power using the switch located on the left side of the machine.
2. Place the machine in Jog Forward mode, and carefully cycle the machine through a complete crimp cycle.
3. Inspect the crimped terminal to verify that the terminal is being positioned properly within the applicator.
4. Correct for any positioning errors according to the instructions supplied with the applicator and repeat Steps 2 and 3 until a terminal is properly positioned.
5. Select the desired mode as described in Paragraph 4.3, Mode Selection.
6. Place a prepared wire in the crimp area and press the foot switch.
7. Inspect the completed crimp and make adjustments as necessary.

4.3. Mode Selection

T-5000 Series Terminating Machines are capable of four primary modes of operation which are accessed through the operator control panel. The current operating mode is indicated by green lights located above the mode button and below the mode icons. The selected mode is indicated by lighting the green light under the mode icon. Select a function by pressing the mode button until the light under the desired icon lights. See Figure 14.

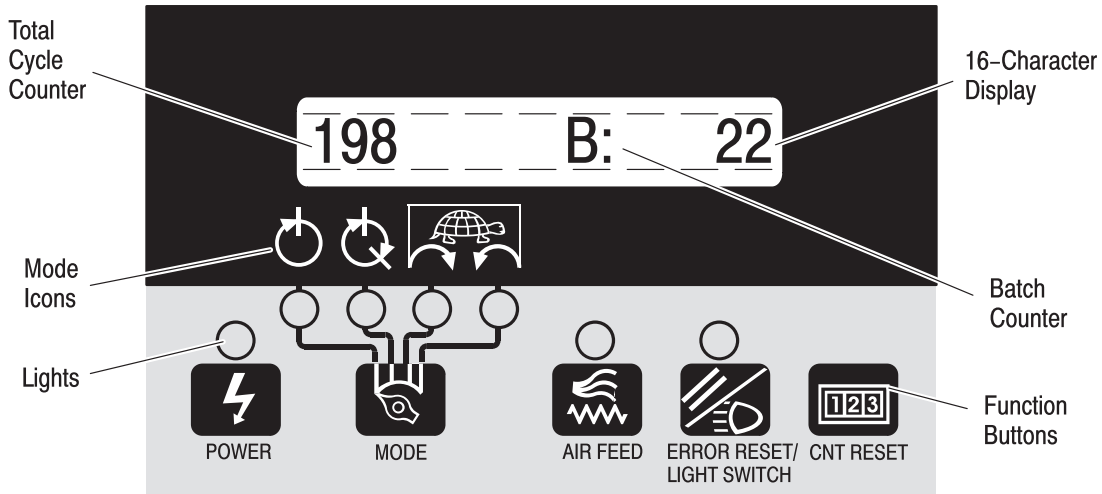

Full Cycle



When the foot switch is depressed in this mode, the crankshaft will rotate at full speed through a full revolution.

Split Cycle



When the foot switch is depressed in this mode, the machine moves the ram down at full speed only far enough for the terminal to be held in the tooling. After wire is inserted into the terminal, the foot switch must be depressed again to complete the cycle and return the ram to the full "up" position.

Jog Mode (Forward)



When the foot switch is depressed in this mode, the crankshaft moves in the forward direction at a reduced speed. The motor is activated only while the foot switch is depressed and held. Power to the motor is removed immediately when the switch is released. When depressing and holding the foot switch, the motor will automatically stop when the ram is fully retracted (top dead center position). The $\rightarrow\rightarrow\rightarrow\rightarrow|^\wedge| \leftarrow\leftarrow\leftarrow\leftarrow$ symbol appears in the display until the foot switch is released.

NOTE *The ram may drift down if the foot switch is released in mid stroke.*

CAUTION *While in JOG mode, attempting to complete a crimp cycle with terminals and wire in the applicator may cause the motor to stall. Although the machine can terminate some smaller terminals and wire, the motor may be unable to complete the cycle. It may be necessary to either reverse jog the machine, or turn off the machine and manually return the ram to the home position.*

Jog Mode (Reverse)

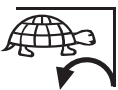

This mode allows a slow speed jog in the reverse direction. Operation is similar to the JOG MODE (Forward).

Figure 14 (cont'd)

**Jog Mode
(Guards Open)**



This mode allows maintenance and setup personnel to slowly jog the machine (forward or in reverse) with the guard doors open. To activate this mode, first place the machine in either the “Jog Forward” or “Jog Reverse” mode. Press and hold the POWER button, then press the MODE button (the message “GUARDS DISABLED” will appear on the display). When both buttons are released, the message will change to “WARN-GUARD OPEN.” The machine will now allow normal forward or reverse jog operation with the guards open. Close the guards to exit this mode.

NOTE

The T-5000 Series Terminating Machine cannot be operated in the full-cycle or split-cycle mode when the guards are open. Depressing the foot switch in full-cycle or split-cycle mode will cause a “CLOSE GUARDS” error which must be reset before the machine will operate. Refer to Section 7, TROUBLESHOOTING.

DANGER

To avoid personal injury, be very careful of moving mechanisms when jogging the machine with the guards open.

Air Feed Mode



Enter the Air Feed menu (machines equipped with optional air feed assembly, only), by pressing and holding the MODE button, then pressing the AIR FEED button. After releasing both buttons, the current Air Feed selection will be displayed. To toggle through selections press the Mode button. When the desired selection is displayed, press the AIR FEED button again. This will save the air feed selection and return the machine to normal operation.

Air Feed Off – Allows the operator to turn off the air feed cylinder, so that the solenoid and valve will not dry cycle (without air) if an air feed applicator is *not* used.

Single Feed – is the standard mode, providing a single 220mS air feed pulse. The machine defaults to Single Feed on first power-up.

Double Feed – provides a second air feed pulse after the first (standard) pulse. The timing is as follows: 220mS on, 220mS off, 220mS on, then off until the next cycle.

Long Air Blast – stretches the single air feed pulse to 440mS.

Language Select Mode



Enter the “Language Select” Mode by pressing and holding the POWER button, then pressing the AIR FEED button. After releasing both buttons, the current language selection will be displayed. Toggle through selections by pressing the ERR RESET button. When the desired selection is displayed, press the AIR FEED button once more to save the new selection and return to normal machine operation.

Light Select Mode



This mode allows maintenance and setup personnel to select and use either the older 12 Vdc worklight, or the newer 24 Vdc worklight. To activate this mode, press and hold the MODE button, then press the CNT RESET button. After releasing both buttons, the worklight will go out and the current worklight selection will be displayed. To toggle through the mode selections, press the MODE button. When the desired mode is displayed, press the CNT RESET button again. This will save the light selection and turn the worklight back on.

Automatic Crimp Height Adjustment Mode



This mode allows setup and maintenance personnel to change the machine crimp height (on TSA-5000 Series Terminating Machines only). To enter the Crimp Height Adjustment Mode, press and hold the MODE button, then press the ERR RESET/LITE button. After both buttons are released, press the MODE button to INCREASE <+> the crimp height, or press the AIR FEED button to DECREASE <-> the crimp height. When the desired crimp height is achieved, press the ERR RESET button to exit the Crimp Height Adjustment Mode.

Figure 14 (end)

4.4. Crimp Height Adjustment Feature

Adjust the crimp height, if necessary, with the procedures described in Paragraph 6.2.

4.5. End-Feed/Side-Feed Conversion

When changing from end-feed to side-feed (or side-feed to end-feed), the reel support assembly must be moved to the opposite side of the machine. With the terminal reel removed, flip the horizontal reel support bar to the opposite side of the machine. Mount the terminal reel on the reel support and load the terminal strip into the applicator. Remove the metal terminal lead-in and thumbscrews and move to the opposite side of the machine. Move the machine lubricator bowl (if applicable) to the opposite side of the machine.

5. PREVENTIVE MAINTENANCE

Preventive maintenance will keep the terminating machine in good working order and ensure maximum reliability and service from all of its components.

DANGER

To avoid personal injury, electrical and pneumatic power must be DISCONNECTED at the source prior to maintenance.

5.1. Cleaning

Clean any debris from the applicator area.

DANGER

Compressed air used for cleaning must be reduced to less than 207kPa [30 psi], and effective chip guarding and personal protective equipment (including eye protection) must be used.

If an air-feed assembly is installed, check and replace the air filter element if necessary.

Remove dust that may have accumulated on the screen covering the motor cooling fan. Periodically *remove* the screen and clean thoroughly.

CAUTION

DO NOT blow air into the screen while the screen is mounted to the machine.

Wipe off the guards with a clean soft cloth.

CAUTION

DO NOT USE ANY SOLVENT TO CLEAN THE GUARDS. Solvent could damage the guards.

5.2. Lubrication (See Figure 15)

The moving parts of the machine require regular lubrication to ensure reliable service and long life. Use only Chevron Ultra EP NLGI No. 2, Pennzoil Pennlith Ultra EP NLGI No. 2, or Conoco Syncon EP Heavy Duty Grease.

NOTE

For operation in temperatures below 10°C [50°F], it will be necessary to use a No. 1 grease.

Using a grease gun, apply grease every 250,000 cycles to the fittings at the following locations:

- The left side of the ram assembly;
- The right side of the ram assembly;
- The left side of the frame just behind the ram assembly;
- The crimp height adjuster pivot.

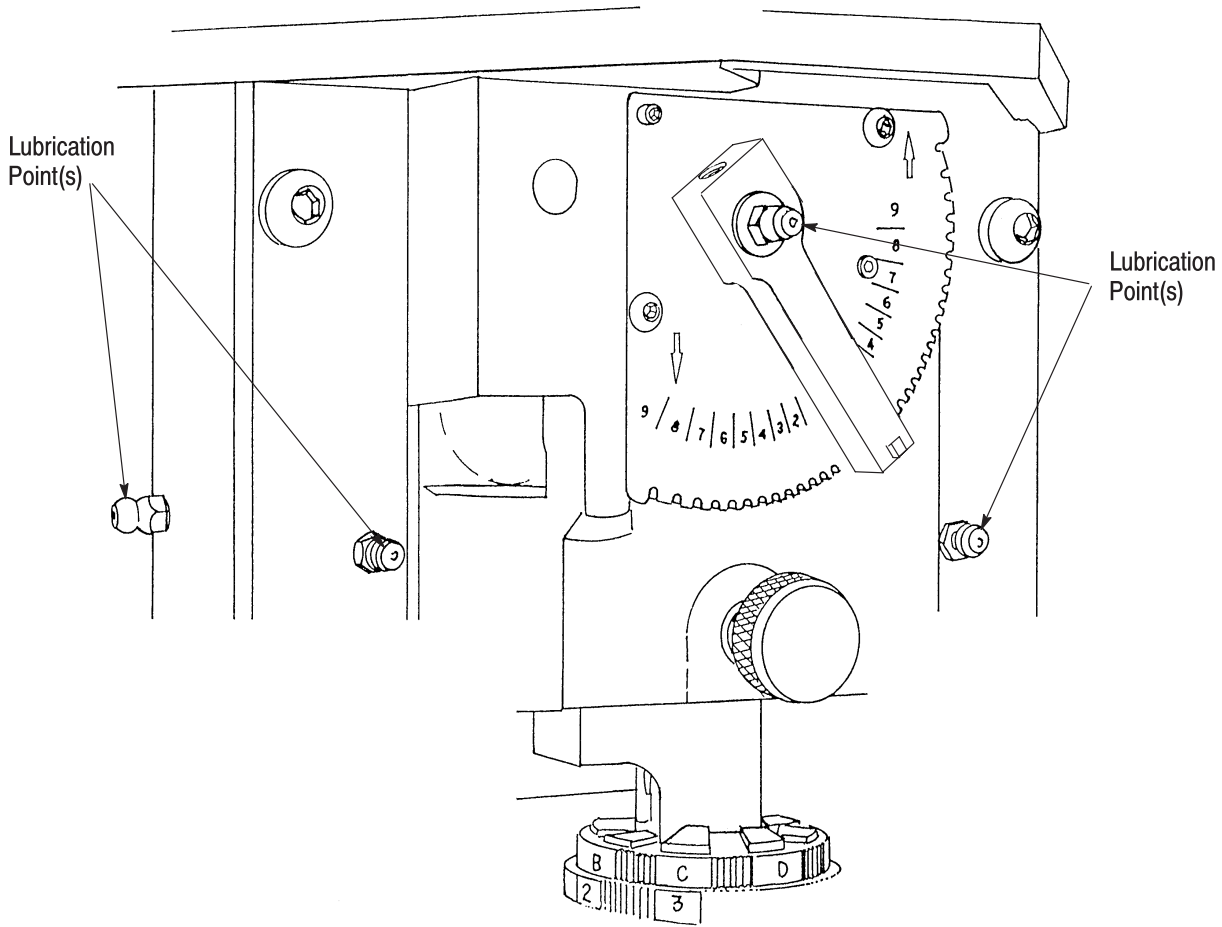

Figure 15

6. ADJUSTMENTS

The following adjustments are necessary to maintain the T-5000 Series Terminating Machine in operating condition, and to set up the machine after replacing parts.

DANGER

To avoid personal injury, ALWAYS disconnect electrical and air supplies before performing adjustments.

6.1. Measuring and Adjusting the Shut Height

The shut height is the distance between the bottom surface of the ram post adaptor and the top surface of the terminating machine base plate. See Figure 16.

NOTE

The shut height is preset at the factory and should not require adjustment unless it is necessary to replace parts. If you suspect a problem with the shut height, contact ATS Customer Service at 1-877-671-2955.

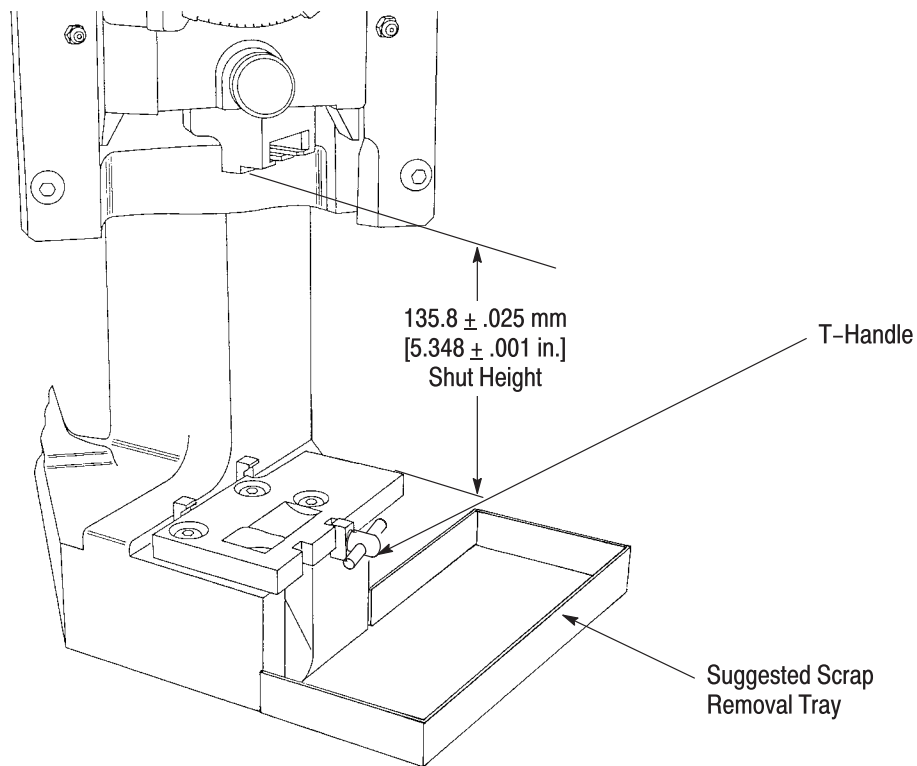

Figure 16

6.2. Crimp Height Adjustment

A. Manual Precision Crimp Height Adjustment

CAUTION To avoid damaging the applicator, ALWAYS return the precision adjustment lever to the “0” position when finished using the applicator.

1. Adjust the manual precision adjustment lever to “0” by tilting the locating lever toward the eccentric pin. See Figure 17.
2. Install the applicator into the terminating machine as described in Paragraph 4.1.
3. Cycle the terminating machine to crimp three sample terminations. Check the crimp height of the samples. If the crimp heights are not correct, adjust the crimp height according to Step 4.
4. Adjust the crimp height by moving the precision adjustment lever:
 - to the right to increase the crimp height; or
 - to the left to decrease the crimp height.

NOTE Moving the precision adjustment lever one increment in either direction will change the crimp height by approximately 0.013 mm [.0005 in.] per step.

5. Repeat Steps 3 and 4 until the appropriate crimp height is obtained.

CAUTION To avoid damaging the applicator, ALWAYS return the manual precision adjustment lever to the “0” position before changing the applicator.

B. Automatic Precision Crimp Height Adjustment -- Auto Adjust

1. Select CQM diagnostics from the main menu of the Crimp Quality Monitor. Select JOG ADJUST MOTOR.

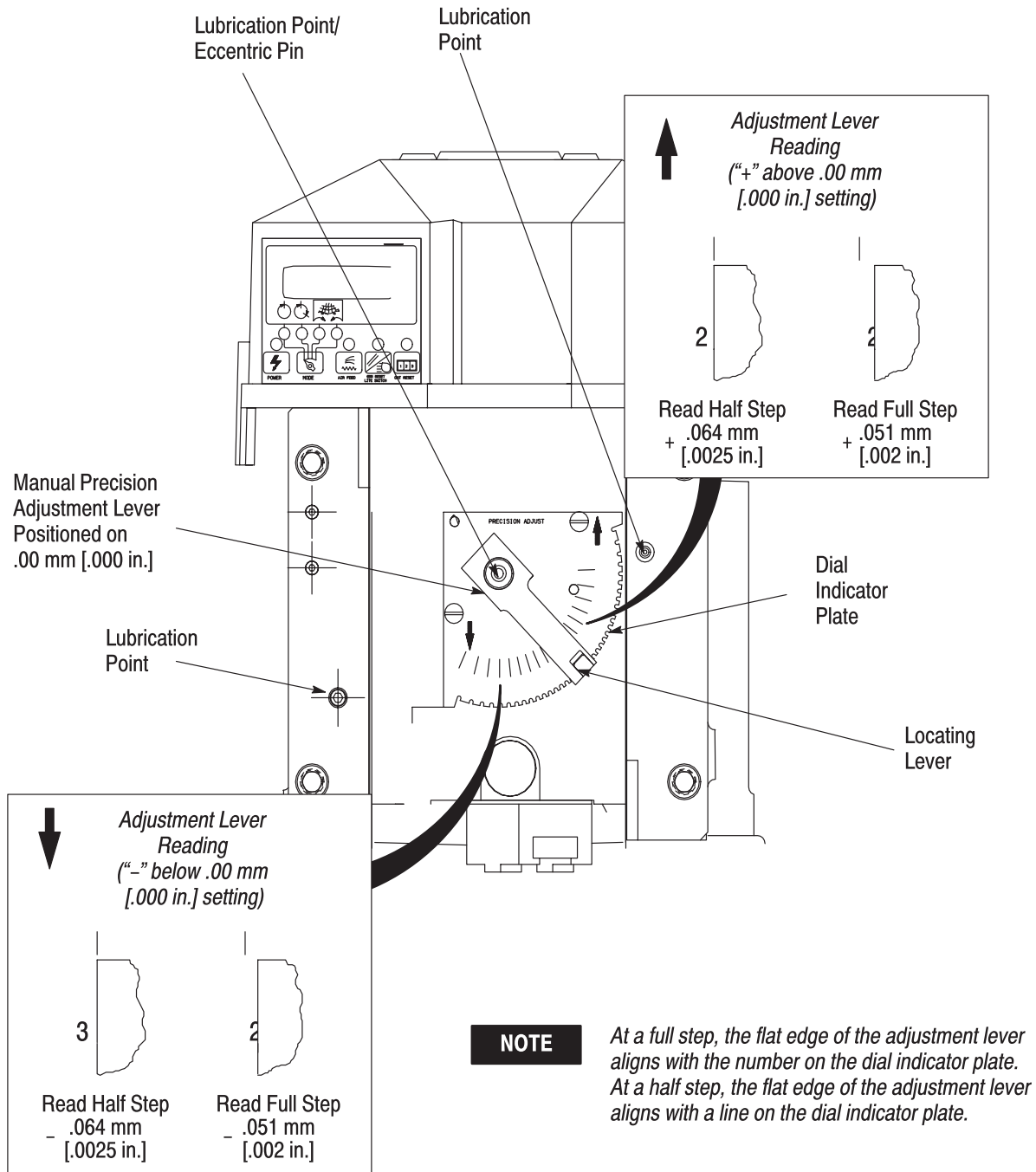

Figure 17

NOTE Refer to the Crimp Quality Monitor customer manual for detailed information regarding this screen.

NOTE Auto Adjust crimp height adjustments can also be made using the terminating machine keypad. See Figure 14.

2. Press the INCREASE CRIMP HEIGHT button or the DECREASE CRIMP HEIGHT button until the dial reads 0.00mm [.00 in.]

NOTE Moving the indicator plate in either direction will change the crimp height by approximately 0.013 mm [.0005 in.] per step. See Figure 18.

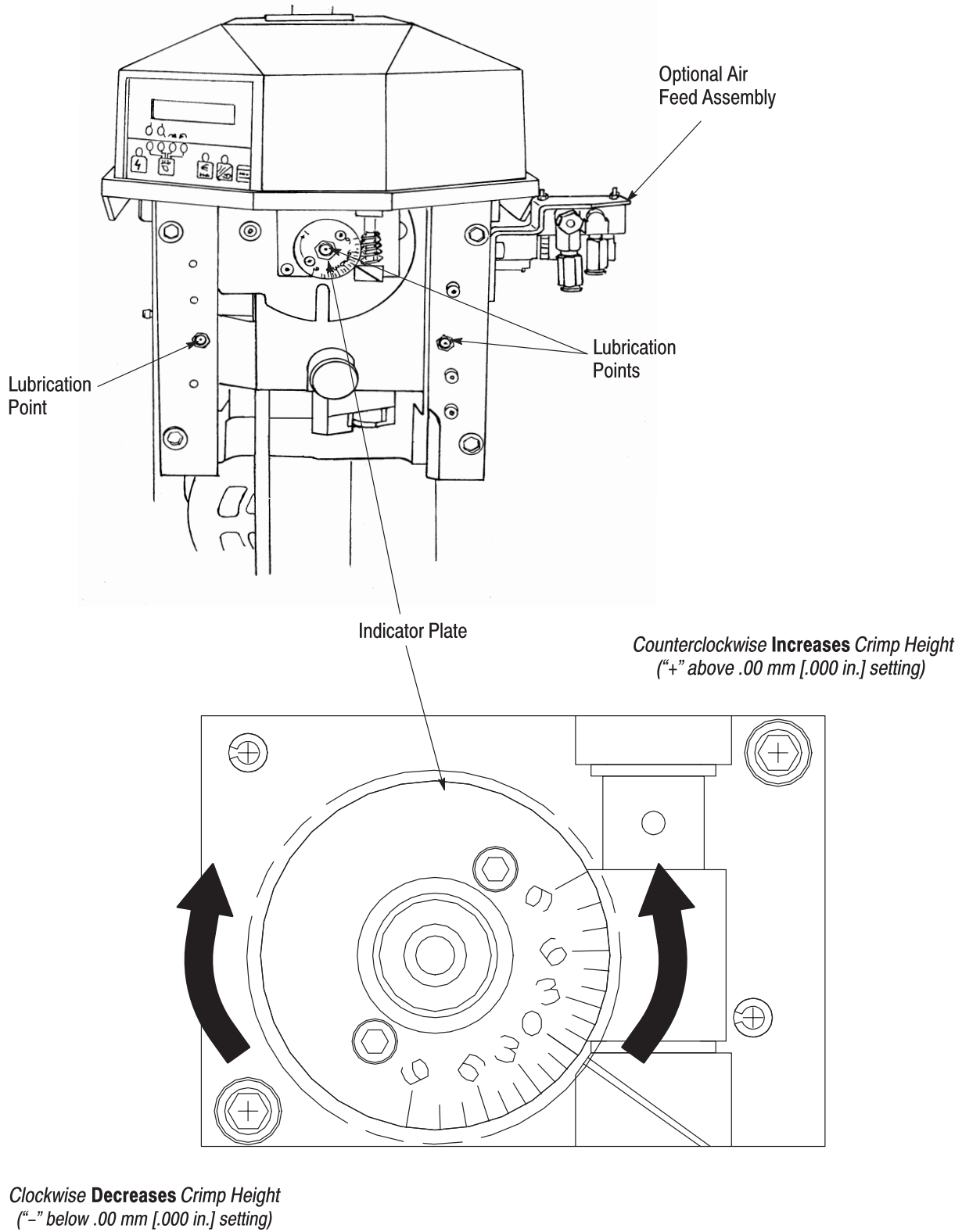

Figure 18

3. Install the applicator into the terminating machine.
4. Secure the applicator ram to the ram post adaptor. Turn the thumbscrew at the front of the ram assembly clockwise until tight.
5. Crimp three sample terminations and check the crimp height.
6. Press the INCREASE CRIMP HEIGHT button or the DECREASE CRIMP HEIGHT button until the desired crimp height is achieved.

CAUTION

To avoid damaging the applicator, ALWAYS return the auto adjust setting to the “0” position before changing the applicator.

6.3. Guard Insert Adjustment

A guard insert is supplied with the machine. Some applications may require a special insert which is included with the applicator. See Figure 19 for standard and tape guard inserts.

The left guard contains two slots into which the inserts can be placed: the rear slot places the insert close to the applicator; the front slot places the insert farther away from the applicator. The type of insert used determines which slot is to be used. An insert placed into the wrong slot cannot be secured in place.

A. Standard Guard Insert PN 679532-1

1. Slide the insert into the rear slot of the left guard door. Secure the insert to the door with two screws placed through the large square holes in the left guard door and into the threaded holes in the top of the insert. Do *not* tighten the screws.

NOTE

The reflective surface must be located at the bottom of the insert facing the operator, with the threaded holes on the top.

2. Move the insert horizontally and vertically as needed to align the slot with the crimp area of the applicator.
3. Tighten the screws.

B. Tape Guard Insert

NOTE

Some special inserts are designed to mount in the standard insert slot. These inserts have the threaded holes at the top corners and should be installed according to the instructions for the standard insert.

1. Slide the insert into the front slot of the left guard door. Secure the insert to the door with two screws placed through the large square holes of the insert and into the threaded holes in the bottom of the left guard door. Do *not* tighten the screws.

NOTE

The reflective surface must be located at the bottom of the insert facing the operator, with two large square holes at the bottom.

2. Move the insert horizontally and vertically as needed to align the slot with the crimp area of the applicator.
3. Tighten the screws.

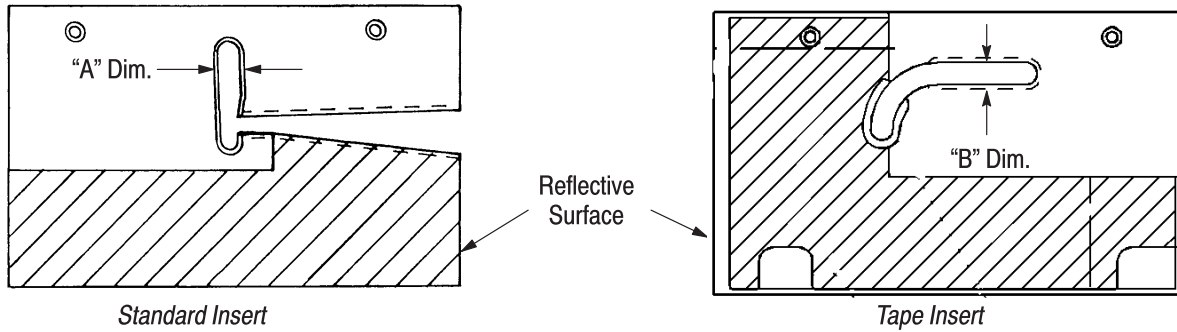

GUARD INSERTS

Insert Part Number	"A" Dim.	"B" Dim.	Description
679532-1	.622 mm [.245 In.]	.508 mm [.200 In.]	Standard (Close to the Applicator) — Shipped with the Machine
354529-1	.779 mm [.307 In.]	.635 mm [.250 In.]	Standard (Away from the Applicator)
679994-1	.622 mm [.245 In.]	.635 mm [.250 In.]	Near Tape
679995-1	.622 mm [.245 In.]	.874 mm [.344 In.]	Away from Tape

Figure 19

6.4. Drive Belt Tension Adjustment

CAUTION

A drive belt that is too tight will cause premature failure of the motor shaft.

The drive belt tension is adjusted by positioning the motor closer to or farther from the upper pulley. Loosen the motor mounting bolts and allow the weight of the motor to tighten the belt. Adjust the tension for 6.48 mm [.255 in.] belt deflection with 66.7N [15 lbs.] applied force at a point 92.96 mm [3.66 in.] from the bottom of the belt. See Figure 20. Tighten the bolts when the adjustment is satisfactory.

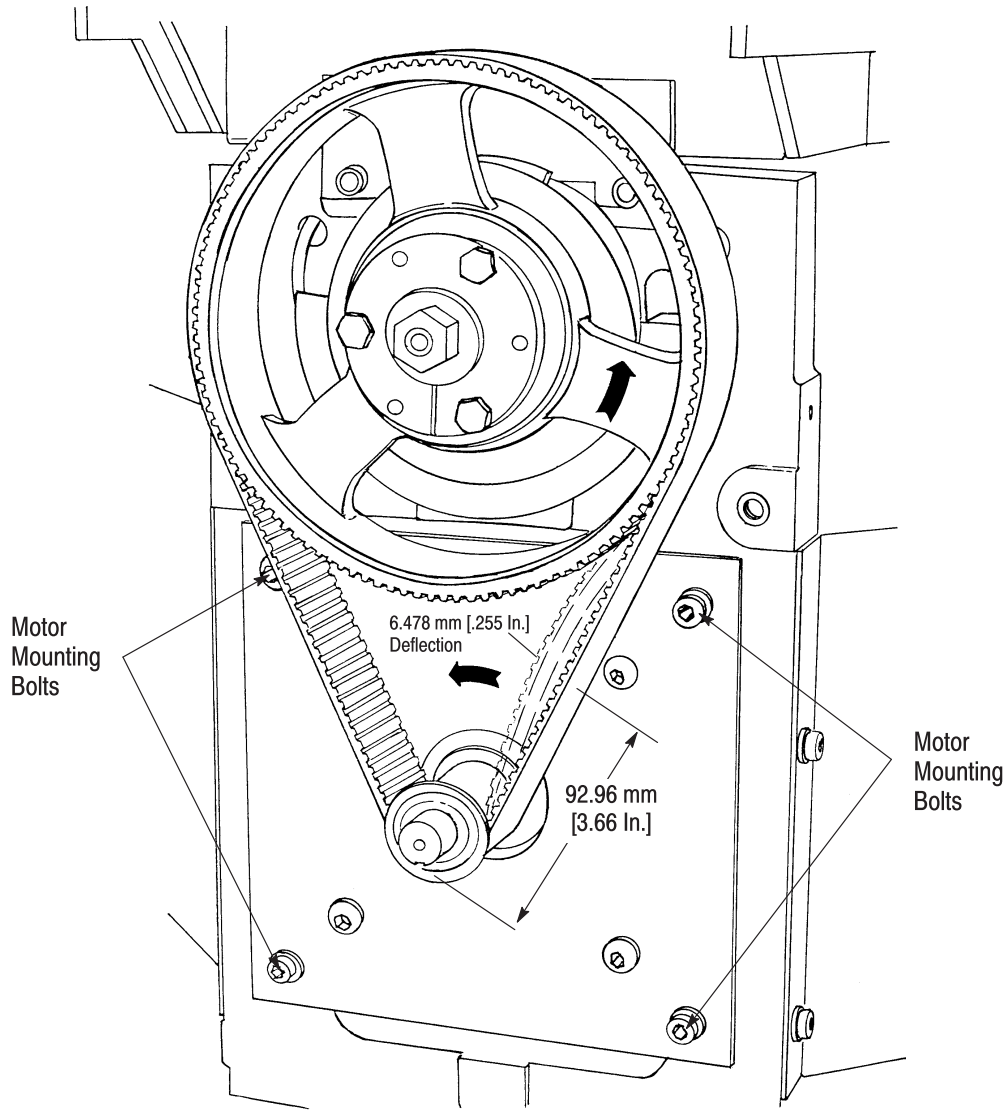

Figure 20

6.5. Light Bulb Replacement

The work light in the machine uses a No. 464 wedge base 28 volt bulb or a No. 655 wedge base 28 volt bulb, available from your local supplier. See Figure 21 and replace the bulb as follows:

1. Open the guard to gain access to the light.
2. Pull the light shroud straight out to remove.
3. Remove the defective light bulb by pulling straight out on the bulb.
4. Press the replacement bulb into the socket.
5. Slide the shroud into position over the bulb.
6. Close the guard.

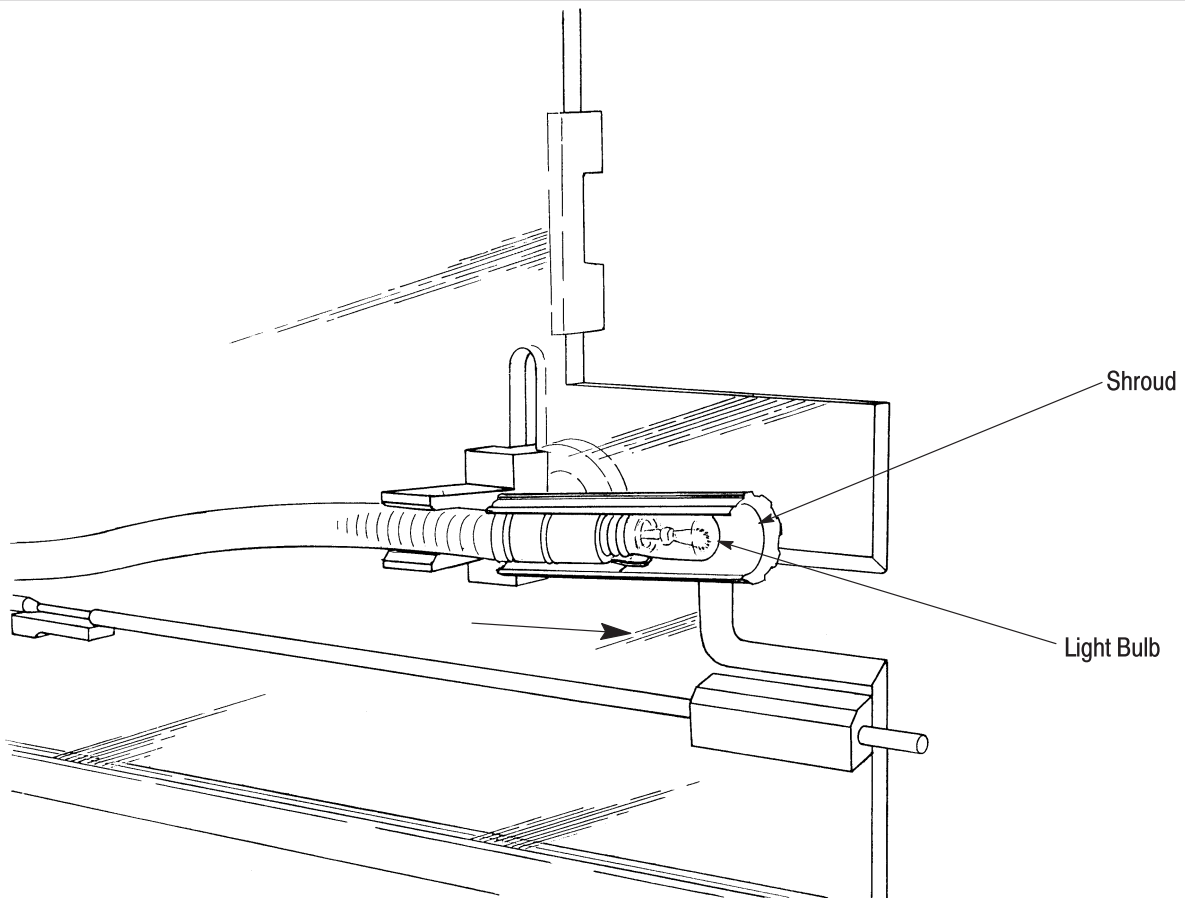

Figure 21

7. TROUBLESHOOTING

DANGER

Dangerously high levels of voltage remain inside the control box for several minutes after the electrical power is interrupted. If access inside the control box is necessary, the following steps must be taken:

- 1. After removing the metal lid from the control box, locate the printed circuit board that is mounted directly behind the circular post in the middle of the box. On this board, locate a red LED labeled “DS2” beside the 2-position connector (labeled “J2”). This LED indicates the level of voltage that remains.*
- 2. If DS2 is lighted, high voltages are still present. Work should not continue until LED DS2 is completely off. The high voltage will dissipate by itself, taking several minutes, with the LED growing dimmer until it goes off altogether.*

PROBLEM	POSSIBLE CAUSE	REMEDY
CLOSE GUARDS	This message is displayed when the guard is opened in the full- or split-cycle mode after the guards have been bypassed.	After closing the guards, this message will be replaced with the Manual Run Screen
CQM ERROR	The terminating machine did not receive a “good” signal from the Crimp Quality Monitor (CQM) for the last termination.	Refer to the CQM display for cause of error. Reset the error on the terminating machine to allow continued operation.
CQM MOTOR FAULT	The auto adjust motor drew too much current when activated.	Inspect motor and gearing for debris or binding. Reset the error on the terminating machine to allow continued operation.
CQM NOT POWERED	The terminating machine detected a CQM that is connected but not powered up (error appears only on initial power up).	Turn on the CQM and reset the error on the terminating machine. If the CQM is not turned on, the terminating machine may be operated normally – the error message will only reappear after the next power up of the terminating machine. Verify that the CQM power cord is securely placed into the back of the CQM and at the electrical source.
CQM NOT READY	The terminating machine detected a CQM that is connected and powered up but is not in the RUN or CALIBRATE mode.	Set the CQM for either the RUN or CALIBRATE mode, reset the error on the terminating machine and retry. NOTE: Without placing the CQM in either the RUN or CALIBRATE mode, the terminating machine can be cycled once by resetting the error and depressing the foot switch. The error message will be re-displayed and the terminating machine must be reset again for another cycle.
EEPROM ERROR	The controller detected a problem with its memory.	Contact an ATS Service Representative. Call Customer Service at 1-877-671-2955.
FOOT SW INPUT ON	While powering up, the terminating machine detected that the foot switch was depressed.	Check the foot switch for proper operation. Using a continuity meter, pins 1 and 2 of the connector should be normally open, and shorted when the switch is depressed.

PROBLEM	POSSIBLE CAUSE	REMEDY
GUARD SW TIMEOUT	This message is displayed when the main guard interlock and the insert guard interlock do not open or close at the same time.	Open and close the guards again, making sure that both interlock switches are cycled at the same time. Reset the error and try cycling the machine again. Clear the error and attempt to cycle the machine.
GUARDS NOT CLOSED	The foot switch was depressed while the guards were opened.	Close the guards, reset the error, and try cycling the machine again.
GUARDS DISABLED	This message appears briefly after pressing the POWER and MODE keys.	No action required
MOTOR FAULTED	This message indicates that the terminating machine detected a problem with the motor drive circuit.	Contact an ATS Service Representative. Call Customer Service at 1-877-671-2955.
MOTOR OVER TEMP	The thermostat, a normally closed switch located inside the fan shroud, opened due to temperatures inside the shroud exceeding 54° C [130° F]. Once this error occurs, the terminating machine cannot be reset until the thermostat again closes.	
	Dirty screen over fan	Check the condition of the screen in front of the fan. If the screen is dirty or clogged, it will restrict the flow of air to the motor, causing the thermostat to open. DANGER: To avoid personal injury, be sure to wear approved eye protection when using compressed air. Remove the screen and blow out dirt with compressed air. (Be sure to remove the screen for this operation or dirt will be blown into the motor, causing shortened motor life).
	Faulty thermostat	The thermostat may be on the lower end of its tolerance, or outside the tolerance, resulting in nuisance tripping, especially when the ambient temperatures are high. Replace the thermostat.
	Fan doesn't operate	If the fan does not run, the heat will build-up inside the shroud, until the thermostat will open. Check the operation of the fan by powering up the machine, then press and hold the CNT RESET button on the control panel. The fan should run for as long as the button is held. If the fan doesn't run, either the fan is bad, the output on the CPU board is bad, the wiring between them is open (see System Schematic), or the 24 Vdc used to operate the fan is not present. Contact an ATS Service Representative. Call Customer Service at 1-877-671-2955 for assistance.

PROBLEM	POSSIBLE CAUSE	REMEDY
MOTOR RELAY OPEN	<p>The motor relay circuit disables the motor drive output, preventing the terminating machine from cycling. Determine if terminating machine “powers up” with the error, or if the error appears after the foot switch has been depressed. Try to reset the error by pressing the ERR RESET button (on the operator keypad). Contact an ATS Service Representative at 1-877-671-2955 for further troubleshooting procedures if the problem has not been solved after checking the following areas.</p>	<p>Check for good ribbon cable connections inside of the control box. Remove the top plastic cover of the machine.</p>
	Loose connections	<p>DANGER: The control box contains high residual voltage after disconnection from the power source. To avoid personal injury, turn off the machine at the main power switch/circuit breaker and disconnect the machine from the power source. Then wait for a minimum of five minutes for the voltage to dissipate before proceeding. Refer to the DANGER statement at the beginning of Section 7.</p> <p>When the voltage has dissipated, remove the metal lid of the control box. Locate the 10-position ribbon cable connecting the capacitor board assembly (right behind the center post of the box) to the driver board assembly (at the very rear of the box), and the 24-position ribbon cable connecting the driver board assembly to the CPU board assembly (in the front of the box). Remove and replace all connections to “wipe off” the contacts. Make sure they are fully seated onto their mating pin headers.</p>

PROBLEM	POSSIBLE CAUSE	REMEDY
SW 1 NOT UNMADE	<p>This message indicates that the terminating machine ram did not move off of top-dead-center after a cycle was initiated with the foot switch.</p>	<p>Remove the top plastic cover of the machine.</p>
	<p>Fuse blown on capacitor board</p>	<p>DANGER: The control box contains high residual voltage after disconnection from the power source. To avoid personal injury, turn off the machine at the main power switch/circuit breaker and disconnect the machine from the power source. Then wait for a minimum of five minutes for the voltage to dissipate before proceeding. Refer to the DANGER statement at the beginning of Section 7.</p>
	<p>When the voltage has dissipated, remove the metal lid and replace the fuse. The fuse is located on the capacitor board assembly (located directly behind the center post of the box). The fuse should be a 10 A time-delay 3AG style.</p>	<p>Outside of the control box, check for a loose or disconnected Main Drive Motor Connector (J5) or one or more contacts that may have backed out of the connector housing. Remove the top plastic cover of the machine.</p>
	<p>DANGER: The control box contains high residual voltage after disconnection from the power source. To avoid personal injury, turn off the machine at the main power switch/circuit breaker and disconnect the machine from the power source. Then wait for a minimum of five minutes for the voltage to dissipate before proceeding. Refer to the DANGER statement at the beginning of Section 7.</p>	<p>When the voltage has dissipated, remove the metal lid of the control box. Check for proper connections with the two-wire cable between the driver board and the capacitor board. Also, check the cable connections at the three .250 quick-disconnect tabs on the driver board to the J5 motor connector.</p>

PROBLEM	POSSIBLE CAUSE	REMEDY
SW 1 NOT UNMADE	(Continued)	
	Broken motor shaft	<p>The motor shaft can break at the bearing behind the face plate inside the motor body. The motor armature will then turn, but the shaft does not, resulting in this error. The shaft failure can be caused by the belt being adjusted too tight. Check and adjust the drive belt as described in Paragraph 6.5. Check for a broken shaft as follows:</p> <p>DANGER: To avoid personal injury, ALWAYS turn “off” the machine at the main power switch/circuit breaker and disconnect the machine from the power source before removing the back cover from the terminating machine.</p> <ol style="list-style-type: none"> 1. Turn “off” the machine and disconnect the machine from the power source. Remove the back plastic cover from the terminating machine. Loosen four screws that hold the motor plate to the frame. Lift up on the motor shaft to loosen and remove the belt. 2. Grip the motor shaft and attempt to quickly spin it a quarter-turn, with a jerking motion. If the shaft is broken, it will slip (or ratchet). Replace the motor if the shaft is broken.
SW 1 NOT MADE, SW 2 NOT MADE	These messages indicate that the machine failed to see the vane switches change state within a certain period of time.	
	Low line voltage	<p>Measure the line voltage at the receptacle where terminating machine is plugged in. Periodic line voltage problems, such as brownouts in the summer, could cause this problem. Running three or more T-5000 Series Terminating Machines (or other heavy current drawing equipment, such as welders or equipment with large motors) on the same branch circuit could cause the line voltage to sag. Try plugging the terminating machine into another branch circuit.</p>
	Applicator problems	<p>Remove the applicator and see if the terminating machine cycles without errors. Try another applicator on the same terminating machine, or try swapping the applicator to another terminating machine, to see if the problem follows the applicator.</p>

PROBLEM	POSSIBLE CAUSE	REMEDY
SW 1 NOT MADE, SW 2 NOT MADE	(Continued)	
	Incorrect motor profile	<p>Turn the terminating machine “off” and “on,” noting what the display reads while it is indicating the software revision. An “L” should be displayed after the revision during North American operation (120 Vac). An “H” should be displayed during international operation (220 Vac). If an “H” is displayed, while the machine is running at 120 Vac, the machine is running the wrong motor profile, which will result in very sluggish operation, culminating in switch errors. Contact an ATS Service Representative at 1-877-671-2955 for further troubleshooting procedures.</p>
	Driver board problems	<p>If one phase of the three-phase drive system is not operating, the terminating machine will run unevenly (lumpy), resulting in switch errors. Remove the top plastic cover of the machine.</p> <p>DANGER: The control box contains high residual voltage after disconnection from the power source. To avoid personal injury, turn off the machine at the main power switch/circuit breaker and disconnect the machine from the power source. Then wait for a minimum of five minutes for the voltage to dissipate before proceeding. Refer to the DANGER statement at the beginning of Section 7.</p> <p>DANGER: To avoid personal injury, ALWAYS turn “off” the machine at the main power switch/circuit breaker and disconnect the machine from the power source before removing the ribbon cable connections.</p> <p>Remove the ribbon cable connections, re-seat them, and see if the problem is corrected. If problems persist, call an ATS Service Representative at 1-877-671-2955 for further troubleshooting procedures.</p>

PROBLEM	POSSIBLE CAUSE	REMEDY
SW 1 NOT MADE, SW 2 NOT MADE	(Continued)	
	Vane switch problems	<p>Check for proper switch alignment of the vane as it rotates through the switch (the vane should not strike the switch). Check to be sure the vane switch connector and all the contacts are fully seated. Check for proper switch operation and supply voltage:</p> <ol style="list-style-type: none"> 1. Do not disconnect the connector. With the terminating machine turned on, use a voltmeter to check the voltage between Pin 1 and Pin 2 (available through the body of the connector, where the lance of the contact is latched). The voltage should read 15 Vdc. 2. On the control panel, press the POWER button to disable terminating machine operation (green LED above button will NOT be lit). Remove the rear plastic cover of the machine so the large pulley can be manually rotated. Turn the pulley so the vane moves in and out of the switch you are checking. With no vane in the gap, the voltage reading between Pins 2 and 3 should be between .03 and .4 Vdc. With a vane in the gap, the voltage should be 15 Vdc. If problems persist, call an ATS Service Representative at 1-877-671-2955 for further troubleshooting procedures.
	Excessive drag	Check applicator and terminating machine for proper lubrication. If necessary, lubricate the machine as described Paragraph 5.2.
WARN:GUARDS OPEN	This message warns the operator that the guards are by-passed. This message is displayed when the guard is opened in the forward jog or reverse jog mode after the guards have been bypassed.	When you are finished jogging the machine with the guards by-passed, close the guards. The display will return to the Normal Run Screen.

8. REVISION SUMMARY

This is an initial release of 417-1 per EC 0990-1568-04. This document supercedes 409-10018.